

TX-29AD2DP/M Service Manual

Safety

Specifications

Parts List

Service
Information

Adjustments

Self Check

Service Hints

Mechanical
View

Disassembly

Location of
Controls

Waveforms

Block Diagrams

Schematic Diagrams

PCB Views

Service Support

Service and repair of this product is supported by Panasonic's LUCI interface.

This interface provides a link between the TV and a standard PC to allow a number of diagnostic and control functions to be performed.

For more details contact your local Panasonic company.

BACK

EXIT

Video / Audio

Control

Dolby

BACK

A - PCB

B - PCB

C - PCB

E - PCB

J - PCB

K - PCB

M - PCB

Y - PCB

A - Schematic

B - Schematic

C - Schematic

E - Schematic

J - Schematic

K - Schematic

M - Schematic

Y - Schematic

BACK

BACK

Service Manual



Colour Television

TX-29AD2DP/M

EURO-2S Chassis

Specifications

Power Source :	220-240V AC 50Hz
Power Consumption :	140W
Standby Power Consumption :	1W
Aerial Impedance :	75Ω unbalanced, Coaxial Type
Receiving System :	PAL- I, PAL 525/60 M.NTSC, NTSC (AV ONLY)
Receiving Channels :	UHF E21 - E69
Intermediate Frequency :	
Video	39.5 MHz
Sound	33.5 MHz
Colour	35.07 MHz (PAL)
Video / Audio Terminals :	
DOLBY SURROUND OUT	Audio(RCA x 5) 500mV rms, 1kΩ
AV1 IN	Video (21 pin) 1V p-p, 75Ω Audio (21 pin) 500mV rms, 10kΩ RGB (21 pin)
AV1 OUT	Video (21 pin) 1V p-p, 75Ω Audio (21 pin) 500mV rms, 1kΩ
AV2 IN	Video (21 pin) 1V p-p, 75Ω Audio (21 pin) 500mV rms, 10kΩ S-Video IN Y : 1V p-p, 75Ω (21 pin) C : 0.3V p-p, 75Ω
AV2 OUT	Video (21 pin) 1V p-p, 75Ω Audio (21 pin) 500mV rms, 1kΩ Selectable output (21 pin)

AV3 IN	S-Video IN Y : 1V p-p, 75Ω (4-pin) C : 0.3V p-p, 75Ω Audio (RCA x 2) 500mV rms, 10kΩ Video (RCA x 1) 1V p-p, 75Ω
High Voltage :	31kV ±1kV at zero beam current
Picture Tube :	68cm Super Flat
Audio Output :	
Internal Speakers	2 x 20W (Front) (Music Power) 8Ω 1 x 25W (3D Bass) (Music Power) 6Ω
External Speakers	2 x 15W (Rear) (Music Power) 8Ω 1 x 20W (Centre) (Music Power) 8Ω
Headphones	8Ω Impedance
Accessories supplied :	Remote Control 2 x UM3 Batteries TS-300DP Speakers & video cabinet
Dimensions :	Height : 570mm Width : 698mm Depth : 483mm
Net Weight	44kg

Specifications are subject to change without notice.
Weight and dimensions shown are approximate.

NOTE : This service manual should be used in conjunction with the EURO 2 technical guide.

Contents

- Safety Precautions
- Location of Controls
- Chassis Service Position
- Self Check
- Adjustment Procedure
- Alignment Procedure
- Waveform Pattern Table
- Block Diagrams
- Exploded Views
- Parts List
- Conductor Views
- Schematic Diagrams

Safety Precautions

General Guide Lines

1. It is advisable to insert an isolation transformer in the AC supply before servicing a hot chassis.
 2. When servicing, observe the original lead dress in the high voltage circuits. If a short circuit is found, replace all parts which have been overheated or damaged by the short circuit.
 3. After servicing, see that all the protective devices such as insulation barriers, insulation papers, shields and isolation R-C combinations are correctly installed.
 4. When the receiver is not being used for a long period of time, unplug the power cord from the AC outlet.
 5. Potentials as high as 32 kV are present when this receiver is in operation. Operation of the receiver without the rear cover involves the danger of a shock hazard from the receiver power supply. Servicing should not be attempted by anyone who is not familiar with the precautions necessary when working on high voltage equipment. Always discharge the anode of the picture to the chassis before handling the tube.
 6. After servicing make the following leakage current checks to prevent the customer from being exposed to shock hazards.
4. Check each exposed Metallic part and check the voltage at each point.
 5. Reverse the AC plug at the outlet and repeat each of the above measurements.
 6. The potential at any point should not exceed 1.4 Vrms. In case a measurement is outside the limits specified, there is a possibility of a shock hazard, and the receiver should be repaired and rechecked before it is returned to the customer.

Leakage Current Cold Check

1. Unplug the AC cord and connect a jumper between the two prongs of the plug.
2. Turn on the receiver's power switch.
3. Measure the resistance value with an ohmmeter, between the jumpered AC plug and each exposed metallic cabinet part on the receiver, such as screw heads, aerials, connectors, control shafts etc. When the exposed metallic part has a return path to the chassis the reading should be between 4M ohm and 20M ohm. When the exposed metal does not have a return path to the chassis the reading must be infinite.

Leakage Current Hot Check

1. Plug the AC cord directly into the AC outlet. Do not use an isolation transformer for this check.
2. Connect a 2k ohm 10W resistor in series with an exposed metallic part on the receiver and an earth such as a water pipe.
3. Use an AC voltmeter with high impedance to measure the potential across the resistor.

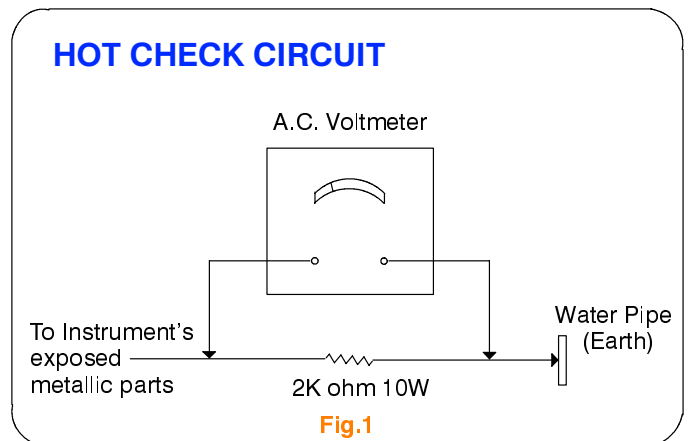

X-Radiation Warning

1. The potential sources of X-Radiation in TV sets are the high voltage section and the picture tube.
2. When using a picture tube test jig for service ensure that the jig is capable of handling 32kV without causing X-Radiation.

NOTE: It is important to use an accurate periodically calibrated high voltage meter

1. Set the brightness to minimum.
2. Measure the high voltage. The meter should indicate 31kV ±1kV at zero beam current if the meter indication is out of tolerance, immediate service and correction is required to prevent the possibility of premature component failure.
3. To prevent an X-Radiation possibility, it is essential to use the specified tube.

Location Of Controls

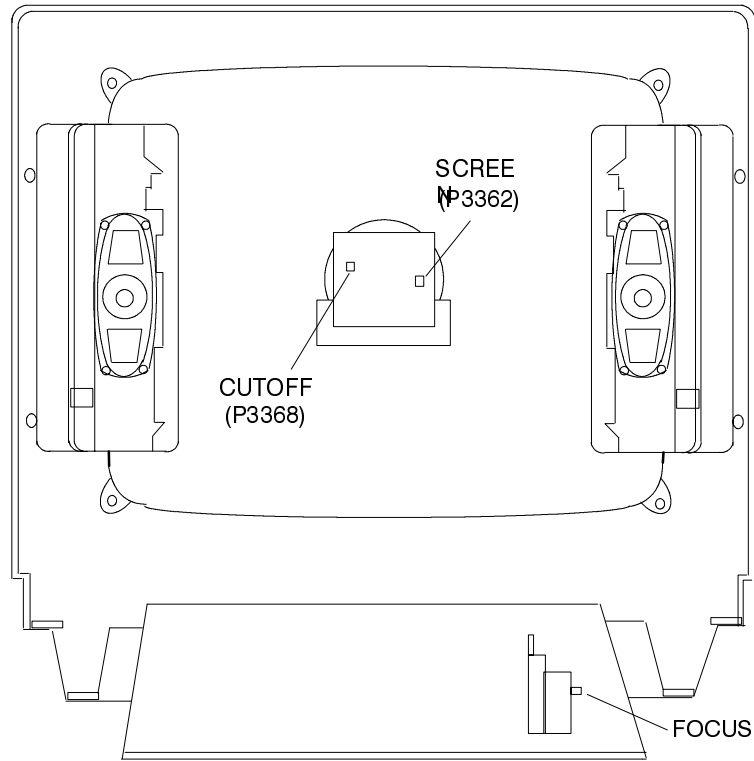
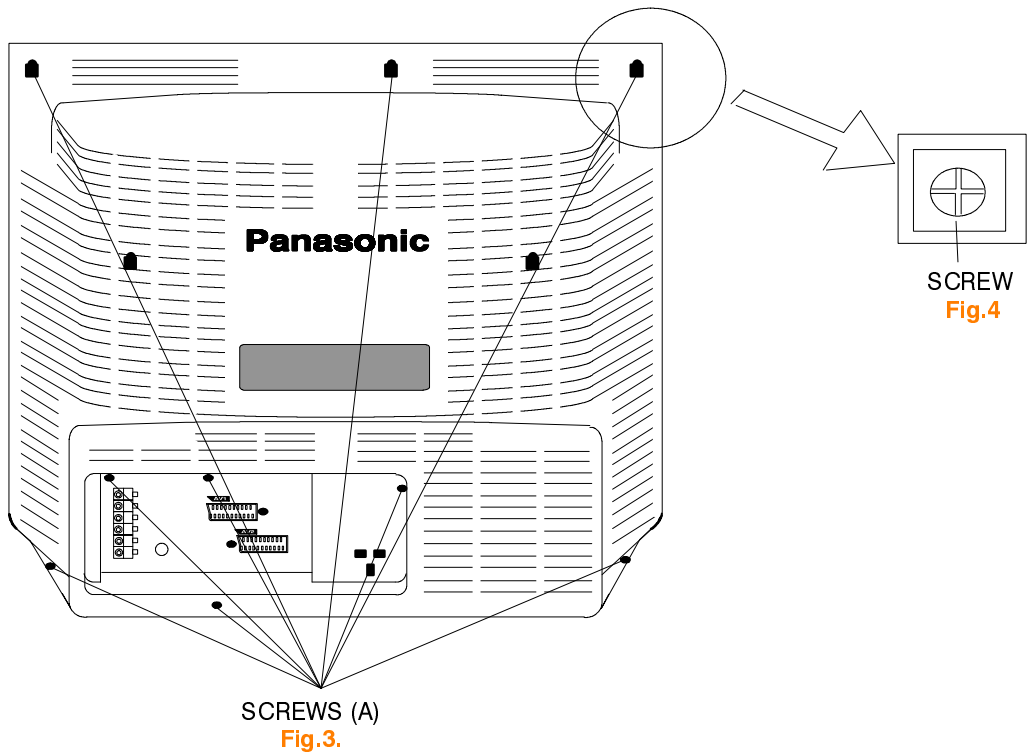

Fig.2

Service Hints

How to remove the rear cover

1. Remove the 9 fixing screws (A) as shown in Fig.3/Fig.4.



How to Remove the Control Panel (M-board)

1. Remove the E-board from the cabinet with the M-board attached.
2. Unclip by lifting the front of the M-board vertically.
3. After servicing ensure all wiring is returned to its original position before returning the receiver to the customer.

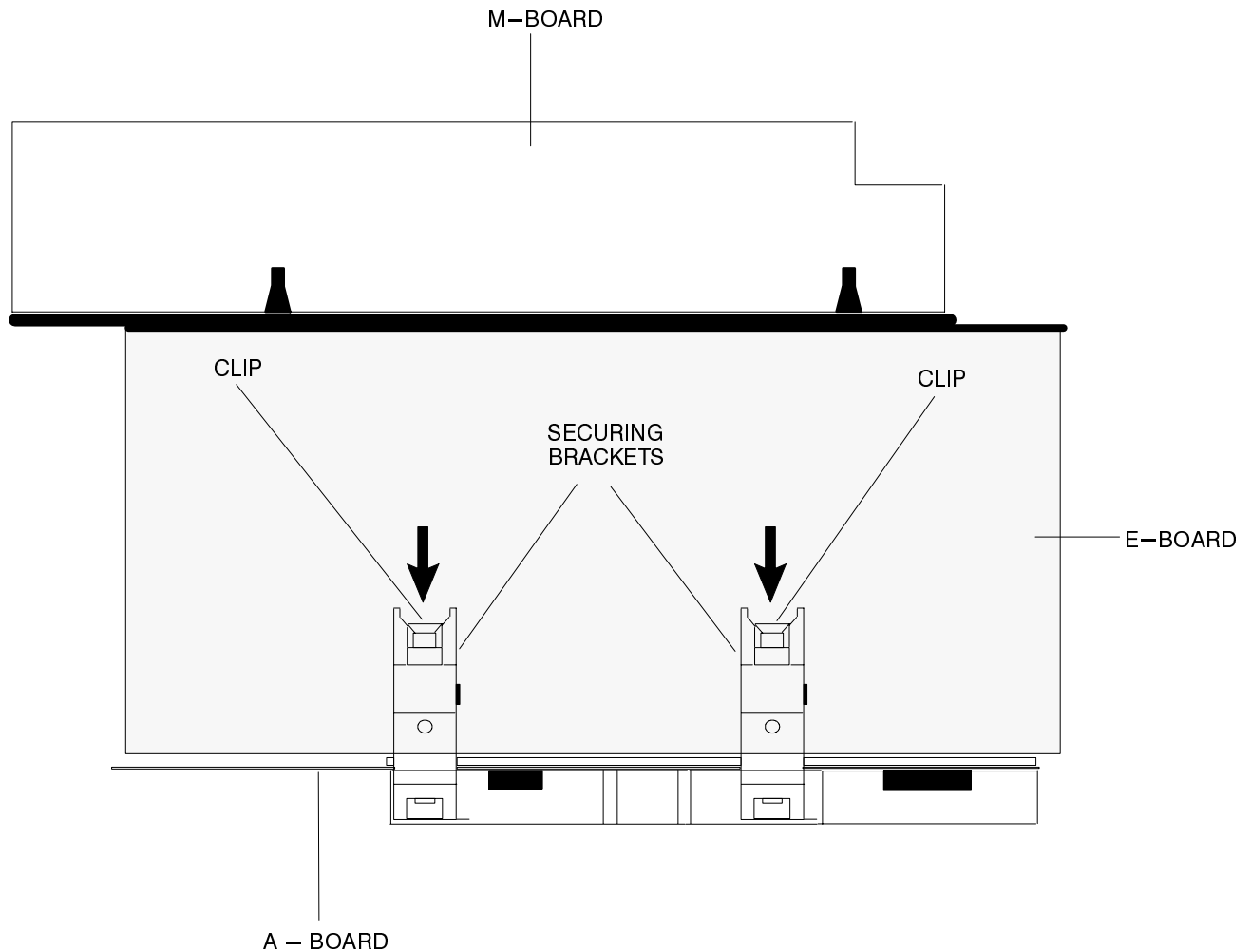

Fig.5

How to Remove the A – Board

1. Disconnect the four leads from the A – board.
2. Release the A board securing brackets by pushing the clips in the direction shown in Fig.5, and remove the A – board by gently lifting vertically.
3. After servicing ensure all wiring is returned to its original position before returning the receiver to the customer.

How to move the chassis into the Service position

1. Hold and lift the rear of the E- PCB chassis as shown in **Fig.6.** and gently pull the chassis toward you.
2. Release the respective wiring clips and turn the chassis through 90°, anti-clockwise, as shown in **Fig.7.**
3. Clip the chassis onto the speaker box as shown in **Fig.8** and **Fig.9.**
4. After servicing ensure all wiring is returned to its original position before returning the receiver to the customer.

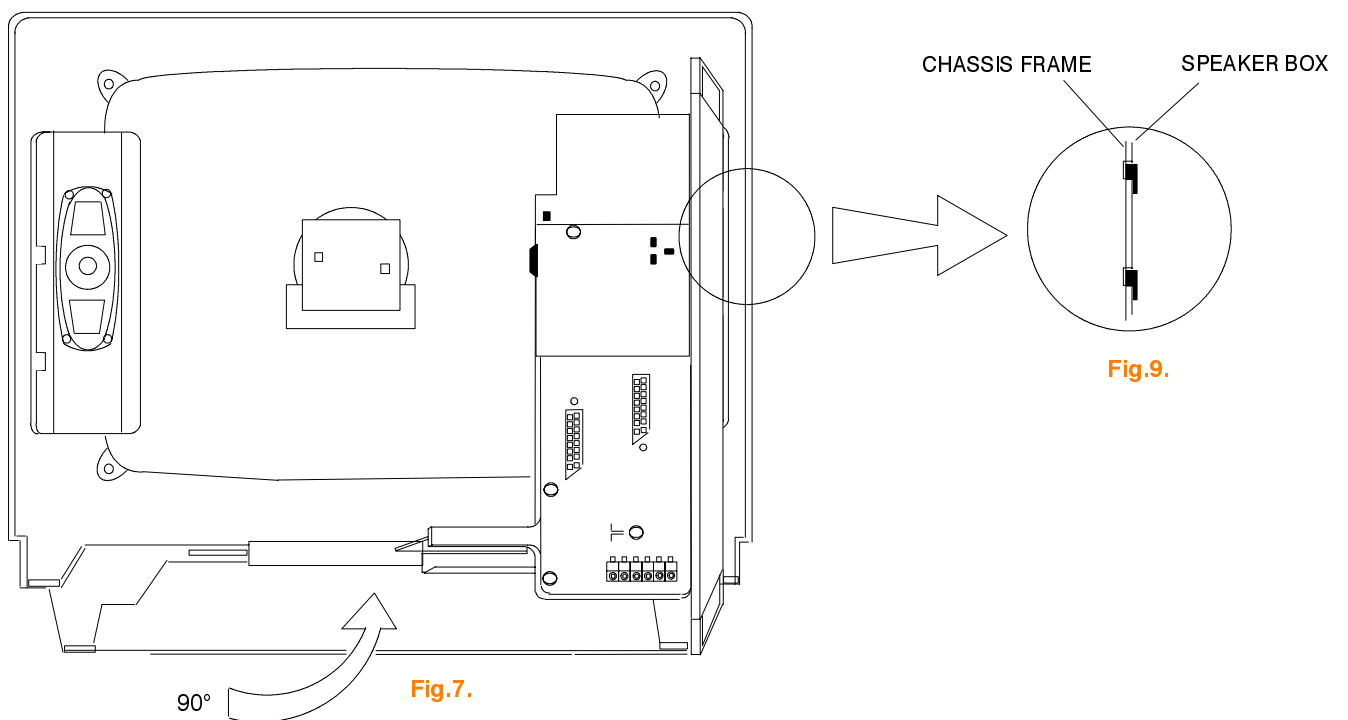
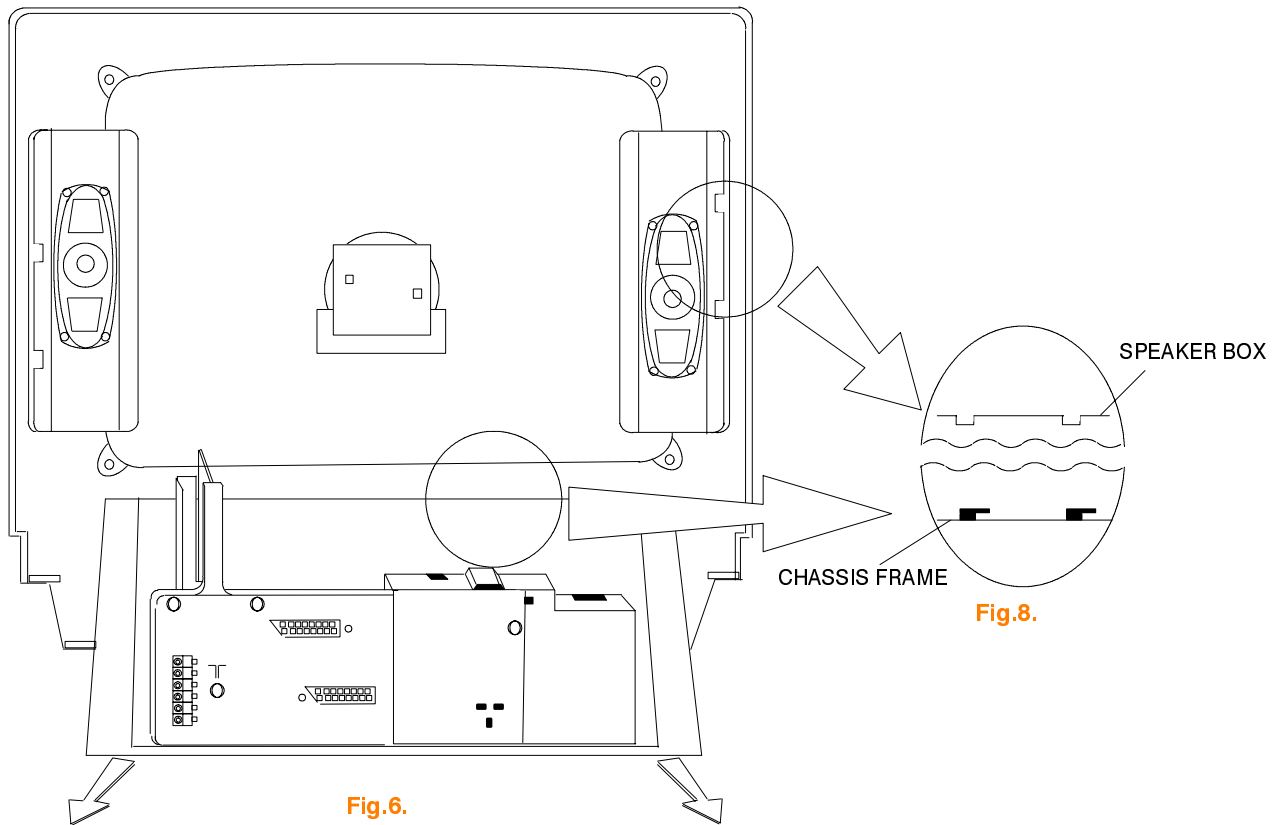

Service position for the A–Board

1. Remove the A–board from the main chassis (E–board), see Fig. 5, ensuring all leads are disconnected.
2. Remove the two screws (A) (Fig.10) from the plastic AV cover and unclip the AV cover from the A–board.
3. Carefully unclip the three metal clips marked B in Fig.10.
4. Unclip the front metal cover (Fig11) and remove from the A–board.
5. For ease of servicing remove the rear metal cover by desoldering (Fig.12)
6. Fit the extension leads to the A–board making sure that the A–board does not touch the E–board (Fig.13).
7. After servicing ensure all wiring is returned to its original position before returning the receiver to the customer.
Note : The extension lead wire kit is supplied as a service kit. (Part number TZS2EP001).

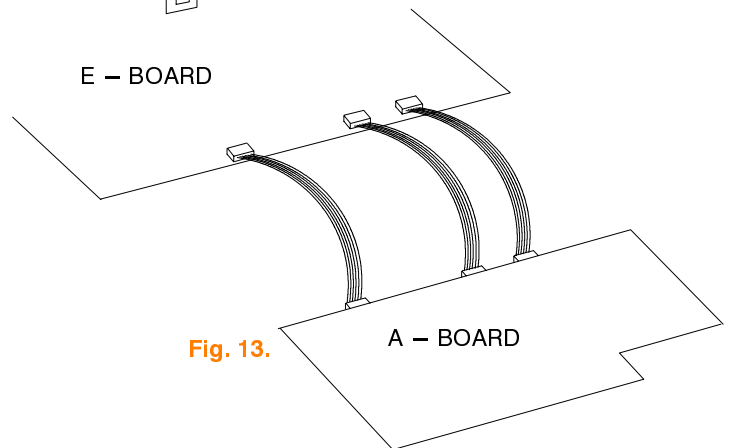
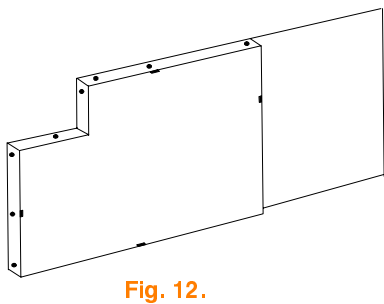
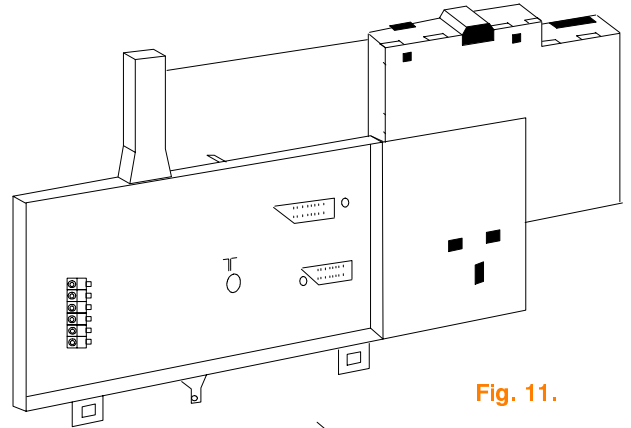
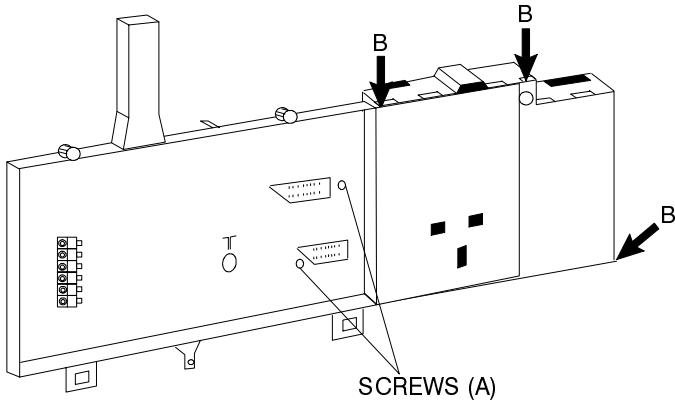

Service Position for the K–Board

SIDE VIEW

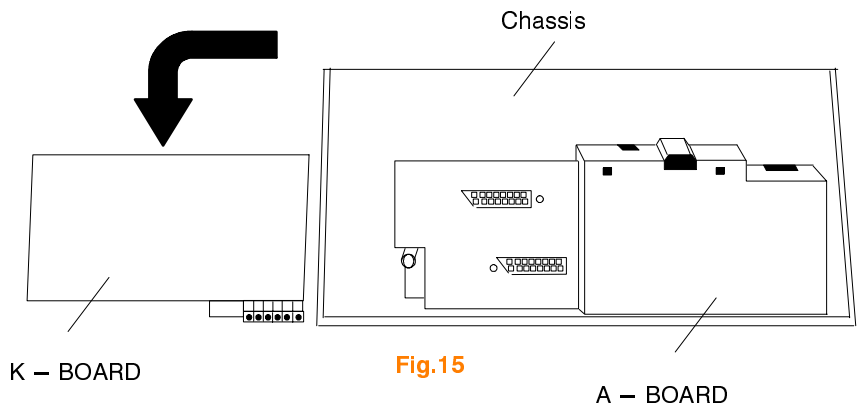
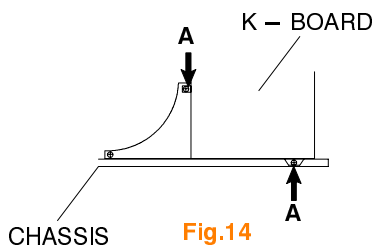

1. Remove the two screws (A) indicated in Fig.14 to release K–Board
2. Slide the K–Board out of the chassis holding position and gently release making sure that the K–board does not touch the E–board.

Service Mode

The remote control is used for entering and storing adjustments, with the exception of cut-off adjustments which must always be done prior to service adjustment. Perform adjustments in accordance with screen display. The display on the screen also specifies the CCU variants as well as the approx. setting values. The adjustment sequence for the service mode is indicated below.

1. Set the Bass to maximum position, set the Treble to minimum position, press the F button followed by the volume down button on the customer controls at the front of the TV and at the same time press the Reveal button on the remote control, this will place the TV into the Service Mode.
2. Press the RED / GREEN buttons to step down / up through the functions.
3. Press the YELLOW / BLUE buttons to alter the function values.
4. Press the STORE button after each adjustment has been made to store the required values.
5. To exit the Service Mode press the Normalisation button.

NOTE: This TV also has the option of using a Memory Pack which enables you to copy the preset TV channels and analogue levels into the Memory Pack and then upload them onto another EURO-2 TV set.

Using the Memory Pack

TV to Memory Pack process

1. Plug the memory pack into the lower of the two 21 pin terminals at the back of the TV and switch the TV on. If the TV has only one 21 pin connector then this will be able to accept the memory pack.

2. Go into the Service Mode as explained above. The screen will show: –

Program
External>>TV

3. Press the blue button on the remote control. The screen will show: –

Program
TV>>External

4. Press the STORE button on the TV. The screen will show: –

Storing

5. All the tuning information stored inside the TV will now be transferred to the Memory Pack. This process will take 2–3 minutes to complete and when finished the screen will show: –

OK!

Memory Pack to TV Process

1. Plug the memory pack into the lower of the two 21 pin terminals at the back of the TV and switch the TV on. If the TV has only one 21 pin connector then this will be able to accept the memory pack.

2. Go into the Service Mode as explained above. The screen will show: –

Program
External>>TV

3. Press the STORE button on the TV. The screen will show: –

Loading

4. All the tuning information stored inside the Memory Pack will now be transferred to the TV. This process will take 2–3 minutes to complete and when finished the screen will show: –

OK!

5. The tuning information from the Memory Pack has now been copied into the TV

6. To exit the Service Mode press the Normalisation button.

7. The process has now been completed and the Memory Pack can now be removed.

Errors

If an error occurs while using the Memory Pack the TV will detect this and the screen will show: –

Program
Error!

If this happens then switch off the TV and repeat the process that was being used. If the errors continue to occur then check the connectors between the TV and the memory pack and check the 9V battery inside the memory pack.

SELF CHECK

Self check is used to automatically check the Bus lines and Hexadecimal code of the TV set.
 To enter the Self Check mode press Function down button, on the Preset Panel, at the same time pressing the Status button on the Remote Control, and the screen will show: –
 When exiting Self Check the customer settings will return to factory settings.

1 — ok	Tuner	11 — ok	Dolby IC for C/R	21 — ok	P SBLED
2 — ok	VIF	12 — ok	P S MODE	22 — ok	P OFF
3 — ok	EEPROM	13 — ok	P TA0	23 — ok	P DEFL
4 — ok	Sound AV switch1	14 — ok	P TA1	24 — ok	P RAM
5 — ok	Video AV switch1	15 — ok	P TA2		
6 — ok	VDP	16 — ok	P TA3		
7 — ok	TPU	17 — ok	P SDA		
8 — ok	MSP	18 — ok	P SCL1		
9 — ok	Dolby Sub	19 — ok	P SCL 3		
10 — --	Dolby IC for L/R	20 — ok	P SCL4		

Hex codes	
04	
CD	
84	
94	
24	

If the CCU ports have been checked and found to be incorrect or not located then "--" will appear in place of "OK".

Adjustment Procedure

Item/Preparation	Adjustments																																																																											
<p>+B SET-UP</p> <ol style="list-style-type: none"> Operate the TV set Set the controls: Brightness minimum Contrast minimum 	<ol style="list-style-type: none"> Set the +B voltage up as follows: Adjust P633 so that U147 shows 147V +/- 0.5V Confirm the following voltages. <table border="0"> <tr> <td>U5</td> <td>5</td> <td>+</td> <td>1/-</td> <td>0.25V</td> </tr> <tr> <td>U5SB</td> <td>5.0</td> <td>+/-</td> <td></td> <td>0.25V</td> </tr> <tr> <td>U8</td> <td>8</td> <td>+/-</td> <td></td> <td>0.5V</td> </tr> <tr> <td>U12</td> <td>12</td> <td>+/-</td> <td></td> <td>0.5V</td> </tr> <tr> <td>U16</td> <td>16.0</td> <td>+</td> <td>0.5/-</td> <td>1V</td> </tr> <tr> <td>U25</td> <td>24.8</td> <td>+/-</td> <td></td> <td>1V</td> </tr> <tr> <td>UM</td> <td>8</td> <td>+/-</td> <td></td> <td>0.5V</td> </tr> <tr> <td>U28</td> <td>28</td> <td>+/-</td> <td></td> <td>1V</td> </tr> <tr> <td>U40</td> <td>38.5</td> <td>+</td> <td>1.5/-</td> <td>1V</td> </tr> <tr> <td>U210</td> <td>209</td> <td>+/-</td> <td></td> <td>10V</td> </tr> <tr> <td>IC2502 Pin3</td> <td>12</td> <td>+/-</td> <td></td> <td>0.5V</td> </tr> <tr> <td>IC2503 Pin3</td> <td>5</td> <td>+/-</td> <td></td> <td>0.25V</td> </tr> <tr> <td>IC2508 Pin3</td> <td>9</td> <td>+/-</td> <td></td> <td>0.3V</td> </tr> <tr> <td>L2503 No Load</td> <td>+20</td> <td>+/-</td> <td></td> <td>1V</td> </tr> <tr> <td>L2503 No Load</td> <td>-20</td> <td>+/-</td> <td></td> <td>1V</td> </tr> </table> 	U5	5	+	1/-	0.25V	U5SB	5.0	+/-		0.25V	U8	8	+/-		0.5V	U12	12	+/-		0.5V	U16	16.0	+	0.5/-	1V	U25	24.8	+/-		1V	UM	8	+/-		0.5V	U28	28	+/-		1V	U40	38.5	+	1.5/-	1V	U210	209	+/-		10V	IC2502 Pin3	12	+/-		0.5V	IC2503 Pin3	5	+/-		0.25V	IC2508 Pin3	9	+/-		0.3V	L2503 No Load	+20	+/-		1V	L2503 No Load	-20	+/-		1V
U5	5	+	1/-	0.25V																																																																								
U5SB	5.0	+/-		0.25V																																																																								
U8	8	+/-		0.5V																																																																								
U12	12	+/-		0.5V																																																																								
U16	16.0	+	0.5/-	1V																																																																								
U25	24.8	+/-		1V																																																																								
UM	8	+/-		0.5V																																																																								
U28	28	+/-		1V																																																																								
U40	38.5	+	1.5/-	1V																																																																								
U210	209	+/-		10V																																																																								
IC2502 Pin3	12	+/-		0.5V																																																																								
IC2503 Pin3	5	+/-		0.25V																																																																								
IC2508 Pin3	9	+/-		0.3V																																																																								
L2503 No Load	+20	+/-		1V																																																																								
L2503 No Load	-20	+/-		1V																																																																								
<p>RF AGC</p> <ol style="list-style-type: none"> Receive a test pattern. Connect an oscilloscope between the tuner RF AGC and ground. Set the oscilloscope gain range to 1V/div. 	<ol style="list-style-type: none"> Check that the noise becomes large when the RF AGC VR P4701 is turned counterclockwise. After the check adjust to previous setting (clockwise). Gradually turn the RF AGC VR anti-clockwise, and set the RF AGC VR to the point where the RF AGC voltage is just falling to a point where this voltage drops by 0.2V from the maximum value. 																																																																											
<p>CUT OFF</p> <ol style="list-style-type: none"> Receive a black and white signal. Degauss the tube externally. Set the TV into Service Mode . Select Ug2 Test. 	<ol style="list-style-type: none"> Confirm which colour has the biggest value. Turn the screen VR P3368 to minimum. Connect an oscilloscope to the cathode with the biggest value colour. Adjust P3368 to get a low light pulse voltage of 150V +/- 5V. Adjust P3362 to whichever colour reaches 50 +/- 10V first. 																																																																											

Alignment Settings (The figures used below are nominal and used for representative purposes only)

Alignment Function	TX-29AD2DP	Settings / Special features
1. Vertical amplitude	V-AMP 154	Optimum setting
2. Vertical symmetry	V-SYM 018	
3. Vertical linearity	V-LIN 015	
4. Vert. D.C.	Vert. D.C. 000	Not to be adjusted
5. V-Pos.	V. Pos. 015	Optimum setting
6. Horizontal amplitude	H-AMP 055	Optimum setting
7. Horizontal position	H-POS 002	
8. Text Position	TEXT POSITION 048	Optimum setting
9. EW-amplitude	E-W-AMP 1 106	Optimum setting
10. EW-amplitude	E-W-AMP 2 037	Optimum setting
11. Trapezium-comp	TRAPEZ-1 144	Optimum setting
12. Trapezium- comp	TRAPEZ-2 034	Optimum setting
13. Colour VCO	Colour VCO 034	Press either Blue or Yellow buttons to effect automatic adjustment
14. Cut-off DC	Cut-off DC 028	Not to be adjusted.
15. Ug2 Test	Ug 2 Test 040 007 090	To adjust the screen settings. Turn P3362 until a colour reaches 25 ± 5 , place an oscilloscope probe on the cathode with the highest output and adjust P3368 so the oscilloscope trace reads 150V 0-peak, then turn P3362 up so the highest numbered box on the TV screen reads 50 ± 10 .
16. Cutoff	Cutoff 052 061 040	Press the GREEN button to step through the settings. Adjust for optimum.
17. White	White 205 218 255	Press the GREEN button to step through the settings. Adjust for optimum.

WAVEFORM PATTERN TABLE

<p>PIN 42 I1601 10u sec/div</p>	<p>PIN 5 W1651 50u sec/div</p>	<p>PIN 1 W1651 10u sec/div</p>	<p>PIN 2 W1651 10u sec/div</p>
<p>PIN 3 W1651 10u sec/div</p>	<p>PIN 44 I1601 10u sec/div (Chroma)</p>	<p>PIN 5 I611 2u sec/div</p>	<p>PIN 7 T639 5u sec/div</p>
<p>PIN 6 I561 5m sec/div</p>	<p>PIN 8 I611 5u sec/div</p>	<p>PIN 8 W511 5m sec/div</p>	<p>PIN 11 W511 5m sec/div</p>
<p>COLLECTOR Q534 64u sec/div</p>	<p>PIN 1 W511 20u sec/div</p>	<p>PIN 6 W511 5m sec/div</p>	<p>BASE Q534 20u sec/div</p>
<p>PIN 4 W511 64u sec/div</p>	<p>COLLECTOR Q594 5m sec/div</p>	<p>PIN 5 I561 5m sec/div</p>	<p>PIN 1 I561 5m sec/div</p>
<p>RED DRIVE 80v</p>	<p>GREEN DRIVE 100v</p>	<p>BLUE DRIVE 120v</p>	

AUDIO BLOCK DIAGRAM

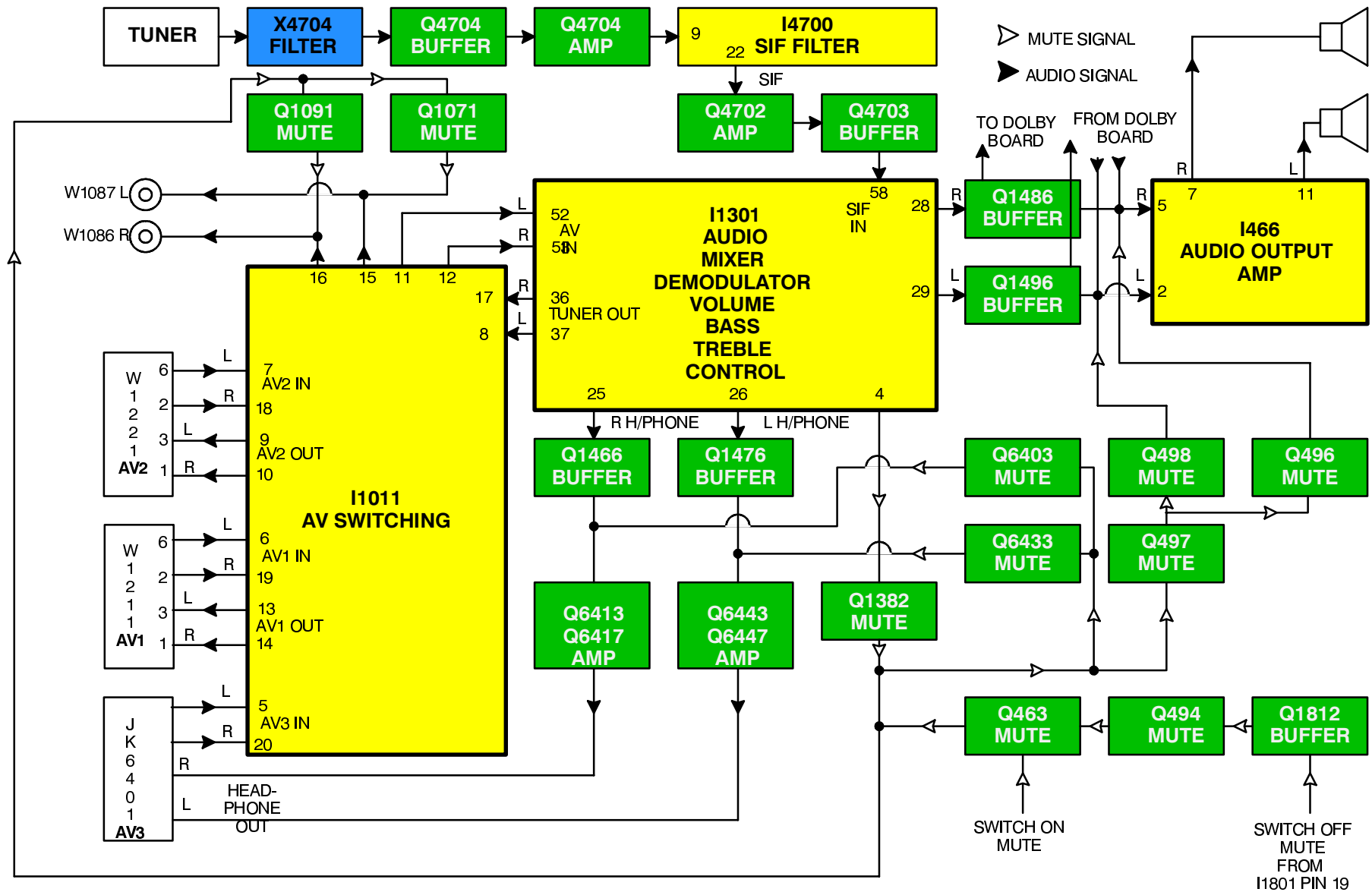

POWER SUPPLY AND CONTROL BLOCK DIAGRAM

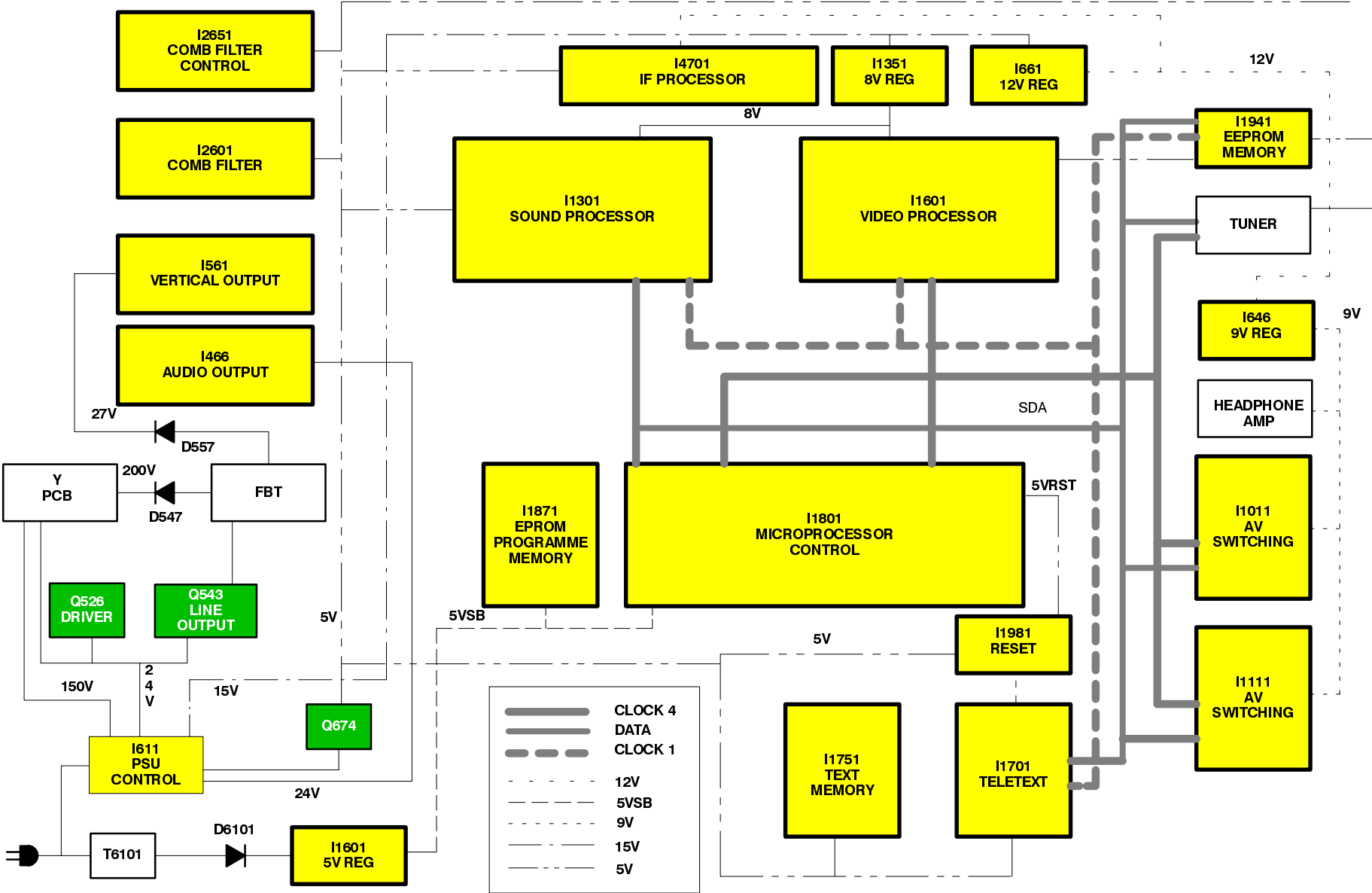

WIRING BLOCK DIAGRAM

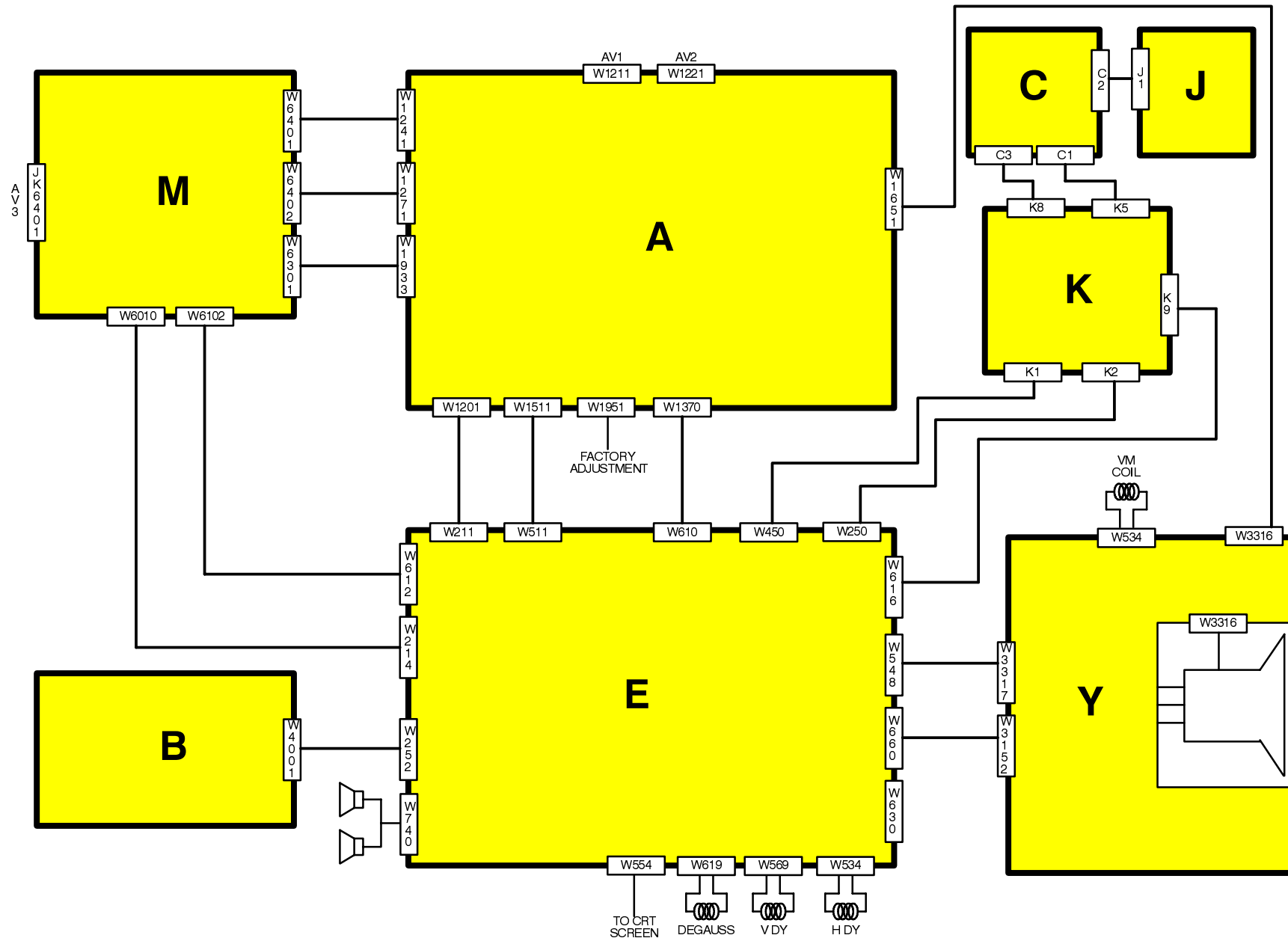

VIDEO BLOCK DIAGRAM

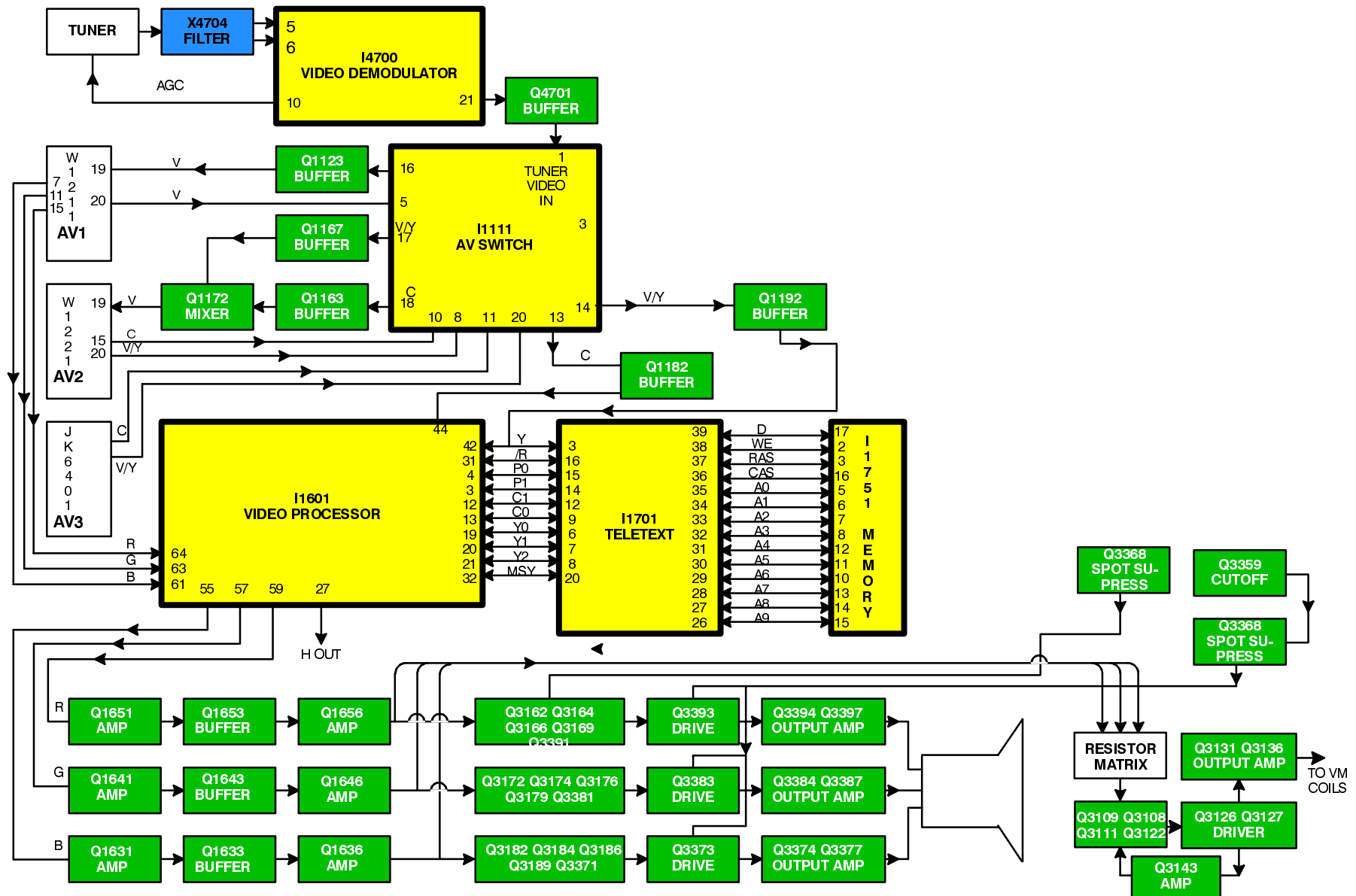

DOLBY PRO LOGIC PROCESSING

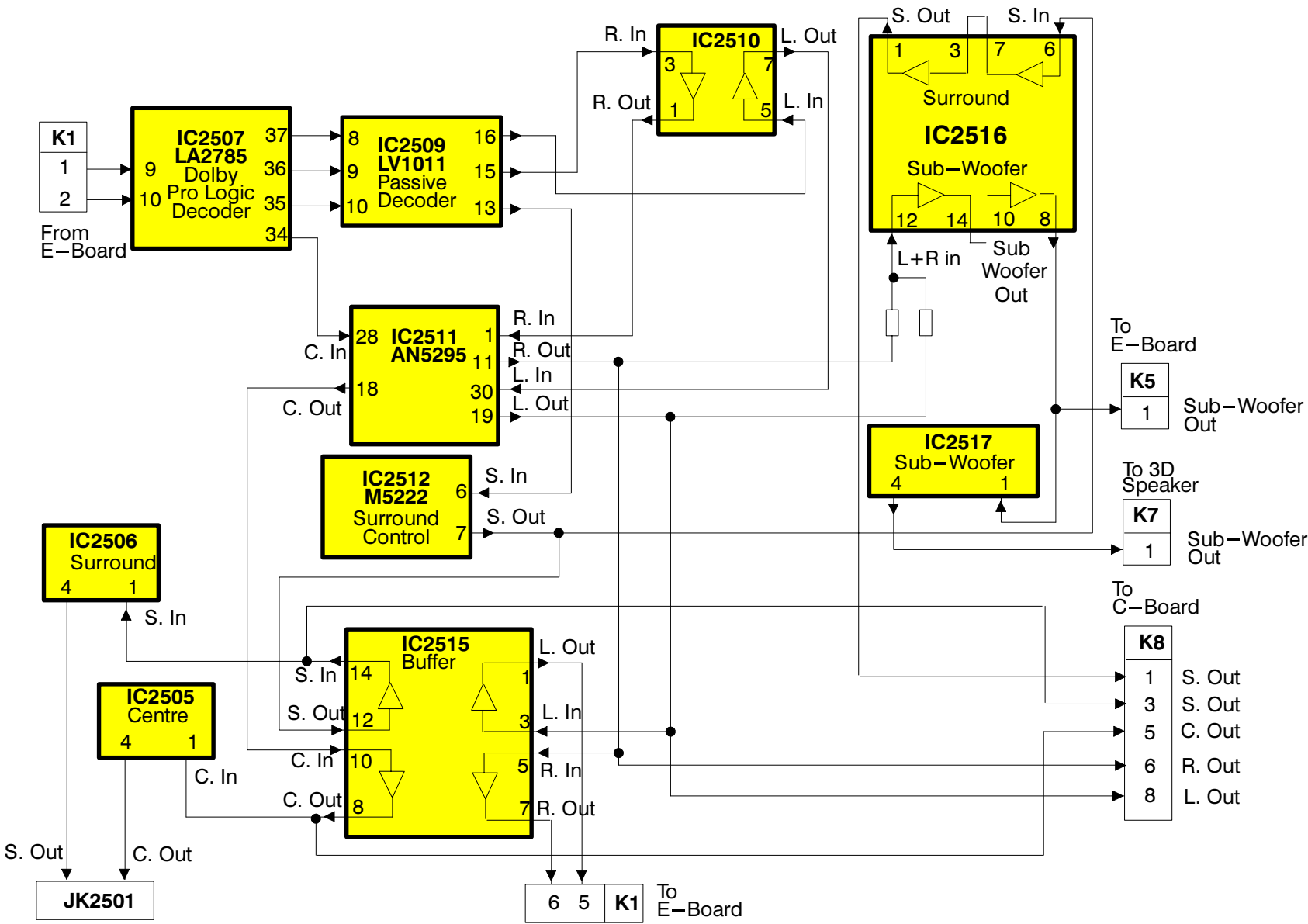

K1

1	9
2	10

From E-Board

IC2507
LA2785
Dolby Pro Logic Decoder

37
36
35
34

IC2509
LV1011
Passive Decoder

16
15
13

IC2510

R. In 3
L. In 7
R. Out 1
L. Out 5

IC2511
AN5295

28
18
1
11
30
19

R. In
R. Out
L. In
L. Out

IC2512
M5222
Surround Control

6
7
S. In
S. Out

IC2506
Surround

4
1
S. In

IC2505
Centre

4
1
S. In
S. Out
C. In

IC2515
Buffer

14
12
10
8
1
3
5
7
L. In
L. Out
R. In
R. Out

IC2516
Sub-Woofer

1
3
7
6
12
14
10
8
S. Out
S. In
L+R in
Sub Woofer Out

IC2517
Sub-Woofer

4
1

JK2501

S. Out
C. Out

K1

6	5
---	---

To E-Board

To E-Board

K5

1

Sub-Woofer Out

To 3D Speaker

K7

1

Sub-Woofer Out

To C-Board

K8

1
3
5
6
8

S. Out
S. Out
C. Out
R. Out
L. Out

PARTS LOCATION

NOTE :

The numbers on the exploded view below refer to the miscellaneous section of the Replacement Parts List.

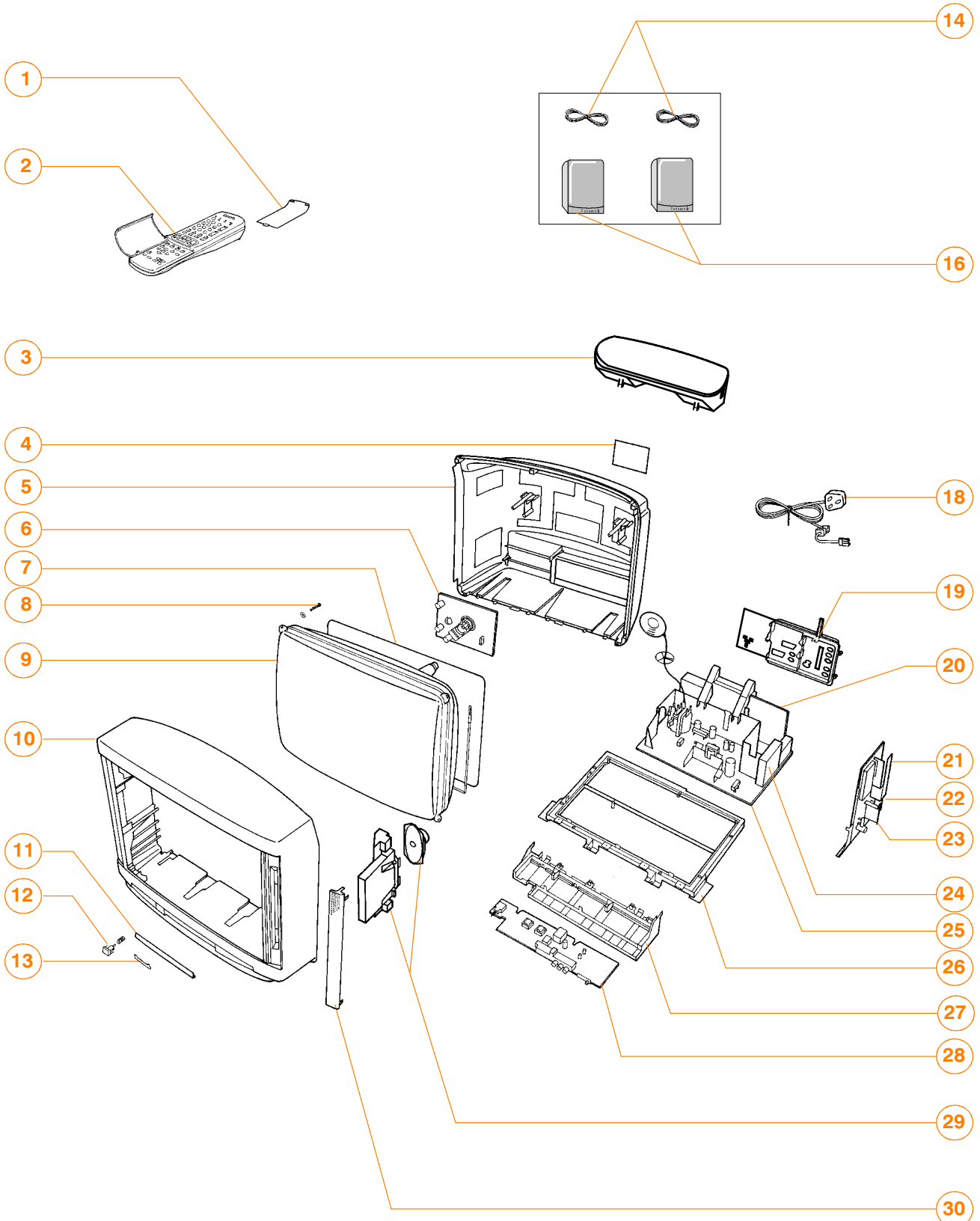

REPLACEMENT PARTS LIST

Important Safety Notice

Components identified by ▲ mark have special characteristics important for safety. When replacing any of these components, use only manufacturer's specified parts.

Ref No.	Part No.	Description
MISCELLANEOUS COMPONENTS		
1)	UR51EC780	BATTERY COVER (REMOTE)
2)	EUR51921	REMOTE CONTROL
3)	EAB10102B2	SUPER 3D BASS SPEAKER
4)	TBM8E1715	MODEL LABEL
5)	TKU8E00270	REAR COVER ▲
6)	TNP117037BG	Y P.C.B. ▲
7)	TLK8E05135	DEGAUSS COIL ▲
8)	THT1009R	CRT FIXING SCREW
9)	A68EHM69X23	C.R.T. ▲
10)	TKY8E081	CABINET ▲
11)	TKP8E1141	DOOR LID
12)	TBX8E032	POWER BUTTON
13)	TBM173052	PANASONIC BADGE
14)	TSX8E0014S	DOLBY SPEAKER WIRE ▲
16)	EAS8E050-B	FRONT SPEAKER COMPLETE
18)	TSX8E0018	POWER CORD ▲
19)	TKP8E1145-1	AV BRACKET
20)	TNP117034CD	A P.C.B. ▲
21)	TNPA0370AA	K P.C.B. ▲
22)	TNPA0458	J P.C.B. ▲
23)	TNP8EC002AA	C P.C.B. ▲
24)	TNP117039AA	B P.C.B. ▲
25)	TNP197087BX	E P.C.B. ▲
26)	TMX8E012	CHASSIS FRAME
27)	TMW8E016-1	CONTROL BLOCK FRAME
28)	TNP8EM012AB	M P.C.B. ▲
29)	EAGG1218E2	SPEAKER
30)	TKP8E1144	SPEAKER NET
	ERC12GK825	SOLID 0.5W 10% 8M2Ω
	TBM8E1532-2	PRESET PANEL
	TBM8E1585	AV DOLBY LABEL
	TEK6940	LID CATCHER
	TKK8E026	SPEAKER REFLECTOR
	TKP8E1143	PANEL LEFT
	U944E/L	TUNER
	TKP8E1155	100HZM PANEL
	TMW8E017	L.E.D.HOLDER
	TPC8E4582	OUTER CARTON
	TPC8E4641	OUTER CARTON
	TPD8E617	CUSHION TOP
	31221212478	FIX CLIP
	TPD8E618	CUSHION BOTTOM
	TPD8E629	CUSHION SET
	TQB8E2485	INST BOOK ▲
	TS-300DP	DOLBY SPK PACK/VIDEO CABINET
	UM-3DEP-2P	BATTERY
INTEGRATED CIRCUITS		
I466	LA4282	AUDIO OUTPUT
I561	TDA8175-3	VERTICAL OUTPUT
I611	TDA4605-3	SWITCHABLE POWER SUPPLY
I646	L78M09MRB	9V REGULATOR
I661	LM317T	12V REGULATOR
I676	TL431ACLPM	COIL
I1011	TEA6420	AUDIO SWITCH
I1111	TEA6415C	VIDEO SWITCH
I1301	MSP3410BPPF7	AUDIO PROCESSOR

Ref No.	Part No.	Description
I1351	AN78L08TA	8V REGULATOR
I1601	VDP3108APPA1	VIDEO PROCESSOR
I1701	TPU3040-20	TEXT PROCESSOR
I1751	81C1000A-70P	DRAM
I1801	CCU3000I-07	CENTRAL CONTROL UNIT
I1802	MN1280R	RESET
I1871	27C010-A09AC	EPROM
I1941	X24D0701AH	EAROM
I1981	MN1280R	RESET
IC2501	STR10006-M	SWITCHABLE POWER SUPPLY
IC2502	L78M12MRB	12V REGULATOR
IC2503	L78M05MRB	5V REGULATOR
IC2505	TDA2030AV	AUDIO AMPLIFIER
IC2506	TDA2030AV	AUDIO AMPLIFIER
IC2507	LA2785	DOLBY ENCODER
IC2508	AN7809FLB	9V REGULATOR
IC2509	LV1011	DOLBY MATRIX
IC2510	BA15218	DIODE
IC2511	AN5295K	AUDIO CONTROL
IC2512	M5222P	SURROUND VOLUME CONTROL
IC2513	SC442013B	MICRO PROCESSOR
IC2514	MN1280R	RESET
IC2515	AN6554	OPERATIONAL AMPLIFIER
IC2516	AN6554	OPERATIONAL AMPLIFIER
IC2517	TDA2030AV	AUDIO AMPLIFIER
I2801	AN6554NSF-E2	OPERATIONAL AMPLIFIER
I4700	LA7577N	V.I.F.
I4701	AN78N12	12V REGULATOR
I4702	TSA5514AT/C2	A.F.C.CONTROL
I6101	AN78L05TA	5V REGULATOR
I6301	RPM-637CBRS1	LED RECEIVER
LINKS		
BC1	ERJ6GEY0R00	S.M.CARB 0.1W 5% 0Ω
BC2	ERJ6GEY0R00	S.M.CARB 0.1W 5% 0Ω
BC4	ERJ6GEY0R00	S.M.CARB 0.1W 5% 0Ω
BC5	ERJ6GEY0R00	S.M.CARB 0.1W 5% 0Ω
B11	ERJ6GEY0R00	S.M.CARB 0.1W 5% 0Ω
B12	ERJ6GEY0R00	S.M.CARB 0.1W 5% 0Ω
B15	ERJ6GEY0R00	S.M.CARB 0.1W 5% 0Ω
B16	ERJ6GEY0R00	S.M.CARB 0.1W 5% 0Ω
B17	ERJ6GEY0R00	S.M.CARB 0.1W 5% 0Ω
B18	ERJ6GEY0R00	S.M.CARB 0.1W 5% 0Ω
B19	ERJ6GEY0R00	S.M.CARB 0.1W 5% 0Ω
CAPACITORS		
C201	ECEA1HFQ101	ELECT 50V 100μF
C202	ECQB1H103J	FILM 50V 10nF
C203	ECA1CM221GB	ELECT 16V 220pF
C204	ECQB1H104J	FILM 50V 100nF
C206	222236516334	FILM 160V 330nF
C209	ECQB1H104J	FILM 50V 100nF
C226	ECQB1H104J	FILM 50V 100nF
C228	ECKC1H102J	CERAMIC 50V 1000pF
C461	ECKC1H821J	CERAMIC 50V 820pF
C462	ECA1EM101GB	ELECT 25V 1μF
C463	ECA1EM471GB	ELECT 25V 470pF
C464	ECQM1H104J	FILM 50V 100nF
C465	ECA1CM470GB	ELECT 16V 47μF

Ref No.	Part No.	Description	
C466	ECEA1HU222	ELECT 50V 2200µF	
C467	ECQB1H103J	FILM 50V 10nF	
C468	ECBT1C222MR3	CAPACITOR 16V 2200µF	
C470	222236516684	FILM 160V 100nF	
C471	ECA1HM010GB	ELECT 50V 1pF	
C472	ECA1CM330GB	ELECT 16V 33pF	
C473	ECEA1EGE222	ELECT 25V 2200µF	
C474	ECQB1H562K	FILM 50V 5.6nF	
C476	ECA1HM4R7GB	ELECT 50V 4.7µF	
C477	ECA1HM010GB	ELECT 50V 1pF	
C479	222236576104	FILM 760V 100nF	
C480	222236516684	FILM 160V 100nF	
C481	ECA1HM010GB	ELECT 50V 1pF	
C482	ECA1CM330GB	ELECT 16V 33pF	
C483	ECEA1EGE222	ELECT 25V 2200µF	
C484	ECQB1H562K	FILM 50V 5.6nF	
C486	ECA1HM4R7GB	ELECT 50V 4.7µF	
C487	ECA1HM010GB	ELECT 50V 1pF	
C489	222236576104	FILM 760V 100nF	
C492	ECA1CM102E	ELECT 16V 1nF	
C495	ECA1EM101GB	ELECT 25V 1µF	
C496	ECA1CM100GB	ELECT 16V 10pF	
C501	ECKC1H103JB	CERAMIC 50V 10nF	
C511	ECQM1H393J	FILM 50V 39nF	
C521	ECEA1HU101	ELECT 50V 100µF	
C524	222236516105	FILM 160V 1µF	
C525	ECKC1H271J	CERAMIC 50V 270pF	
C527	ECQM2683JZ	FILM 250V 68nF	
C531	ECQM2564KZ	FILM 250V 560nF	
C534	ECWH12H562J	CERAMIC 1250V 5600pF	▲
C536	ECWH12H103J	FILM 1250V 10nF	▲
C537	ECQF273JZH	FILM 400V 27nF	
C538	ECWF2H514J	FILM 500V 510nF	▲
C541	ECWF2H105J	FILM 500V 1000nF	▲
C543	ECA2VM2R2B	ELECT 350V 2R2µF	
C544	ECKC3D152J	CERAMIC 2KV 1.5nF	▲
C547	ECKC2H101J	CERAMIC 500V 100pF	▲
C548	ECEA2EU220	ELECT 250V 22µF	
C549	ECEA2AU2R2	ELECT 100V 2.2µF	
C557	ECKC2H101J	CERAMIC 500V 100pF	▲
C558	ECA1VM102GB	ELECT 35V 1nF	
C561	ECEA1VU222	ELECT 35V 2200µF	
C562	222236576104	FILM 760V 100nF	
C563	ECA1VM471GB	ELECT 35V 470pF	
C564	ECQB1H473K	FILM 50V 47nF	
C565	ECKC2H151J	CERAMIC 500V 150pF	▲
C567	ECQB1H223K	FILM 50V 22nF	
C568	222236516224	FILM 160V 220nF	
C574	ECEA1VU332	ELECT 35V 3300µF	
C576	ECQM1H684J	FILM 50V 680nF	
C577	222236516105	FILM 160V 1µF	
C578	222236516154	FILM 160V 150nF	
C579	ECKC1H472J	CERAMIC 50V 4.7nF	
C583	ECQB1H333J	FILM 50V 33nF	
C591	ECA1HW4R7UE	ELECT 50V 4.7µF	
C592	ECA1CM330GB	ELECT 16V 33pF	
C593	ECKC1H103JB	CERAMIC 50V 10nF	
C594	ECKC1H103JB	CERAMIC 50V 10nF	
C595	ECQB1H102J	FILM 50V 1nF	
C596	ECQE2474KFW	FILM 200V 470nF	
C597	ECQB1H332K	FILM 50V 3.3nF	
C618	ECOS2GG181NG	ELECT 400V 180µF	▲
C619	ECQE6104K	FILM 600V 100nF	▲
C620	ECKC2H561J	CERAMIC 500V 560pF	▲
C622	ECEA1HFS470	ELECT 50V 47µF	
C623	222236516224	FILM 160V 220nF	
C626	ECKC3D471JB	CERAMIC 2KV 470pF	▲
C628	ECKC1H221J	CERAMIC 50V 220pF	
C629	ECQB1H153K	FILM 50V 15nF	
C631	ECQB1H472J	FILM 50V 4.7nF	
C632	ECQB1H103J	FILM 50V 10nF	
C634	ECEA1HGE010	ELECT 50V 1µF	

Ref No.	Part No.	Description	
C636	ECKC2H472J	CERAMIC 500V 4.7nF	▲
C637	ECQB1H222J	FILM 50V 2200pF	
C638	ECQF6333JZH	FILM 600V 33nF	
C639	ECKWNA152MECC	CERAMIC 1.5nF	
C647	222236516334	FILM 160V 330nF	
C650	ECKC3A471J	CERAMIC 1KV 470pF	▲
C651	ECOS2EA221AB	ELECT 250V 220µF	
C656	ECKC2H681J	CERAMIC 500V 680pF	▲
C657	ECEA1HU471	ELECT 50V 470µF	
C661	ECKC2H821J	CERAMIC 500V 820pF	▲
C662	ECA1VM222GE	ELECT 35V 2.2nF	
C666	222236516224	FILM 160V 220nF	
C667	ECA1CM471GB	ELECT 16V 470pF	
C671	ECKC2H681J	CERAMIC 500V 680pF	▲
C672	ECA1VM222GE	ELECT 35V 2.2nF	
C677	ECA1CM471GB	ELECT 16V 470pF	
C681	ECEA1EGE101	ELECT 25V 100µF	
C682	ECKC2H331J	CERAMIC 500V 330pF	▲
C687	ECEA1HGE102	ELECT 50V 1000µF	
C1001	ECA1CM470GB	ELECT 16V 47µF	
C1002	ECUV1H104ZFX	S.M.CAP 50V 100nF	
C1011	ECA1CM470GB	ELECT 16V 47µF	
C1012	ECUV1H473ZFX	S.M.CAP 50V 47nF	
C1013	ECA1CM470GB	ELECT 16V 47µF	
C1019	ECA1CM470GB	ELECT 16V 47µF	
C1020	ECA1CM470GB	ELECT 16V 47µF	
C1021	ECA1HMR47GB	ELECT 50V 0.47µF	
C1022	ECA1HMR47GB	ELECT 50V 0.47µF	
C1023	ECUV1H221JCX	S.M.CAP 50V 220pF	
C1024	ECUV1H221JCX	S.M.CAP 50V 220pF	
C1031	ECEA1HNR47	ELECT 50V 0.47µF	
C1032	ECA1HMR47GB	ELECT 50V 0.47µF	
C1033	ECUV1H221JCX	S.M.CAP 50V 220pF	
C1034	ECUV1H221JCX	S.M.CAP 50V 220pF	
C1036	ECA1CM470GB	ELECT 16V 47µF	
C1038	ECA1CM470GB	ELECT 16V 47µF	
C1041	ECUV1H103KBX	S.M.CAP 50V 10nF	
C1042	ECUV1H103KBX	S.M.CAP 50V 10nF	
C1043	ECA1HMR47GB	ELECT 50V 0.47µF	
C1044	ECA1HMR47GB	ELECT 50V 0.47µF	
C1045	ECUV1H560JCX	S.M.CAP 50V 56pF	
C1051	ECEA1HNR33	ELECT 50V 0.33µF	
C1052	ECEA1HNR33	ELECT 50V 0.33µF	
C1101	ECA1HMR47GB	ELECT 50V 0.47µF	
C1111	ECA1HM470GB	ELECT 50V 47µF	
C1112	ECUV1H473ZFX	S.M.CAP 50V 47nF	
C1116	ECUV1H473ZFX	S.M.CAP 50V 47nF	
C1121	ECA1HMR47GB	ELECT 50V 0.47µF	
C1124	ECUV1H473ZFX	S.M.CAP 50V 47nF	
C1126	ECA1CM470GB	ELECT 16V 47µF	
C1151	ECUV1H102KBX	S.M.CAP 50V 1nF	
C1158	ECA1HMR47GB	ELECT 50V 0.47µF	
C1161	ECUV1H102KBX	S.M.CAP 50V 1nF	
C1178	ECUV1H473ZFX	S.M.CAP 50V 47nF	
C1179	ECA1CM470GB	ELECT 16V 47µF	
C1183	ECUV1H104ZFX	S.M.CAP 50V 100nF	
C1193	ECUV1H104ZFX	S.M.CAP 50V 100nF	
C1226	ECUV1H560JCX	S.M.CAP 50V 56pF	
C1231	ECUV1H104ZFX	S.M.CAP 50V 100nF	
C1241	ECUV1H472KBX	S.M.CAP 50V 4.7nF	
C1242	ECUV1H472KBX	S.M.CAP 50V 4.7nF	
C1263	ECUV1H102KBX	S.M.CAP 50V 1nF	
C1271	ECUV1H102KBX	S.M.CAP 50V 1nF	
C1273	ECA1HMR47GB	ELECT 50V 0.47µF	
C1282	ECA1HMR47GB	ELECT 50V 0.47µF	
C1284	ECA1HMR47GB	ELECT 50V 0.47µF	
C1301	ECA1CM100GB	ELECT 16V 10pF	
C1302	ECUV1H104ZFX	S.M.CAP 50V 100nF	
C1303	ECA1CM100GB	ELECT 16V 10pF	
C1304	ECUV1H104ZFX	S.M.CAP 50V 100nF	
C1306	ECA1HM101GB	ELECT 50V 100pF	
C1307	ECUV1H104ZFX	S.M.CAP 50V 100nF	

Ref No.	Part No.	Description			
C1309	ECA1CM100GB	ELECT	16V	10pF	
C1310	ECA1CM100GB	ELECT	16V	10pF	
C1311	ECUV1H104ZFX	S.M.CAP	50V	100nF	
C1312	ECEA50Y3R3	ELECT	50V	3.3µF	
C1313	ECUV1H471JCX	S.M.CAP	50V	470pF	
C1314	ECUV1H471JCX	S.M.CAP	50V	470pF	
C1315	ECA1CM100GB	ELECT	16V	10pF	
C1316	ECUV1H104ZFX	S.M.CAP	50V	100nF	
C1321	ECUV1H010CCX	S.M.CAP	50V	1pF	
C1322	ECUV1H010CCX	S.M.CAP	50V	1pF	
C1326	ECQM1H334J	FILM	50V	330nF	
C1327	ECUV1H221JCX	S.M.CAP	50V	220pF	
C1331	ECUV1H391JCX	S.M.CAP	50V	390pF	
C1332	ECUV1H391JCX	S.M.CAP	50V	390pF	
C1346	ECUV1H221JCX	S.M.CAP	50V	220pF	
C1347	ECUV1H221JCX	S.M.CAP	50V	220pF	
C1351	ECA1CM470GB	ELECT	16V	47µF	
C1352	ECUV1H104ZFX	S.M.CAP	50V	100nF	
C1353	ECUV1H104ZFX	S.M.CAP	50V	100nF	
C1371	ERJ6GEY0R00	S.M.CARB	0.1W	5%	∞Ω
C1377	ECUV1H104ZFX	S.M.CAP	50V	100nF	
C1382	ECUV1H104ZFX	S.M.CAP	50V	100nF	
C1409	ECUV1H470JCX	S.M.CAP	50V	47pF	
C1411	ECUV1H070DCX	S.M.CAP	50V	7pF	
C1412	ECUV1H100DCX	S.M.CAP	50V	10pF	
C1413	ECUV1H220JCX	S.M.CAP	50V	22pF	
C1416	ECUV1H070DCX	S.M.CAP	50V	7pF	
C1417	ECUV1H560JCX	S.M.CAP	50V	56pF	
C1444	ECUV1H102KBX	S.M.CAP	50V	1nF	
C1454	ECUV1H102KBX	S.M.CAP	50V	1nF	
C1463	ECUV1H102KBX	S.M.CAP	50V	1nF	
C1465	ECUV1H560JCX	S.M.CAP	50V	56pF	
C1467	ECUV1H102KBX	S.M.CAP	50V	1nF	
C1468	ECUV1H102KBX	S.M.CAP	50V	1nF	
C1473	ECUV1H102KBX	S.M.CAP	50V	1nF	
C1475	ECUV1H560JCX	S.M.CAP	50V	56pF	
C1483	ECUV1H102KBX	S.M.CAP	50V	1nF	
C1487	ECUV1H103KBX	S.M.CAP	50V	10nF	
C1493	ECUV1H102KBX	S.M.CAP	50V	1nF	
C1497	ECUV1H103KBX	S.M.CAP	50V	10nF	
C1601	ECA1CM470GB	ELECT	16V	47µF	
C1602	ECUV1H103KBX	S.M.CAP	50V	10nF	
C1606	ECA0JM102GB	ELECT	6.3V	1nF	
C1607	ECUV1H103KBX	S.M.CAP	50V	10nF	
C1608	ECUV1H040CCX	S.M.CAP	50V	4pF	
C1609	ECUV1H040CCX	S.M.CAP	50V	4pF	
C1611	ECA1CM470GB	ELECT	16V	47µF	
C1612	ECUV1H103KBX	S.M.CAP	50V	10nF	
C1613	ECA1CM100GB	ELECT	16V	10pF	
C1614	ECUV1H473ZFX	S.M.CAP	50V	47nF	
C1615	ECUV1H103KBX	S.M.CAP	50V	10nF	
C1616	ECUV1H101JCX	S.M.CAP	50V	100pF	
C1617	ECUV1H470JCX	S.M.CAP	50V	47pF	
C1618	ECUV1H470JCX	S.M.CAP	50V	47pF	
C1619	ECUV1H103KBX	S.M.CAP	50V	10nF	
C1620	ECUV1H102KBX	S.M.CAP	50V	1nF	
C1621	ECUV1H103KBX	S.M.CAP	50V	10nF	
C1622	ECA0JM102GB	ELECT	6.3V	1nF	
C1625	ERJ6GEYJ151	S.M.CARB	0.1W	5%	150Ω
C1626	ECUV1H104ZFX	S.M.CAP	50V	100nF	
C1627	ECEA1HNR47	ELECT	50V	0.47µF	
C1628	ECA0JM102GB	ELECT	6.3V	1nF	
C1641	ECUV1H104ZFX	S.M.CAP	50V	100nF	
C1651	ECUV1H104ZFX	S.M.CAP	50V	100nF	
C1652	ECUV1H104ZFX	S.M.CAP	50V	100nF	
C1653	ECUV1H104ZFX	S.M.CAP	50V	100nF	
C1655	ECA1CM470GB	ELECT	16V	47µF	
C1661	ECUV1H102KBX	S.M.CAP	50V	1nF	
C1662	ECUV1H683ZFX	S.M.CAP	50V	68nF	
C1663	ECUV1H102KBX	S.M.CAP	50V	1nF	
C1666	ECUV1H102KBX	S.M.CAP	50V	1nF	
C1667	ECUV1H683ZFX	S.M.CAP	50V	68nF	

Ref No.	Part No.	Description			
C1668	ECUV1H104ZFX	S.M.CAP	50V	100nF	
C1672	ECA0JM101G	ELECT	6.3V	100pF	
C1673	ECUV1H104ZFX	S.M.CAP	50V	100nF	
C1681	ECUV1H102KBX	S.M.CAP	50V	1nF	
C1682	ECUV1H102KBX	S.M.CAP	50V	1nF	
C1685	ECUV1H102KBX	S.M.CAP	50V	1nF	
C1686	ECUV1H271JCX	S.M.CAP	50V	270pF	
C1687	ECUV1H121JCX	S.M.CAP	50V	120pF	
C1688	ECUV1H471JCX	S.M.CAP	50V	470pF	
C1691	ECUV1H104ZFX	S.M.CAP	50V	100nF	
C1692	ECUV1H104ZFX	S.M.CAP	50V	100nF	
C1693	ECUV1H104ZFX	S.M.CAP	50V	100nF	
C1696	ECUV1H102KBX	S.M.CAP	50V	1nF	
C1697	ECUV1H100DCX	S.M.CAP	50V	10pF	
C1698	ECUV1H102KBX	S.M.CAP	50V	1nF	
C1699	ECUV1H100DCX	S.M.CAP	50V	10pF	
C1701	ECA1CM470GB	ELECT	16V	47µF	
C1702	ECUV1H103KBX	S.M.CAP	50V	10nF	
C1704	ECA1CM470GB	ELECT	16V	47µF	
C1706	ECUV1H104ZFX	S.M.CAP	50V	100nF	
C1714	ECUV1H103KBX	S.M.CAP	50V	10nF	
C1717	ECUV1H102KBX	S.M.CAP	50V	1nF	
C1721	ECUV1H473ZFX	S.M.CAP	50V	47nF	
C1722	ECUV1H102KBX	S.M.CAP	50V	1nF	
C1752	ECUV1H103KBX	S.M.CAP	50V	10nF	
C1753	ECA1CM100GB	ELECT	16V	10pF	
C1801	ECUV1H103KBX	S.M.CAP	50V	10nF	
C1802	ECA0JM471GB	ELECT	6.3V	470pF	
C1804	ECUV1H103KBX	S.M.CAP	50V	10nF	
C1811	ECUV1H332KBX	S.M.CAP	50V	3.3nF	
C1816	ERJ6GEYJ153	S.M.CARB	0.1W	5%	15KΩ
C1826	ERJ6GEYJ153	S.M.CARB	0.1W	5%	15KΩ
C1836	ECUV1H104ZFX	S.M.CAP	50V	100nF	
C1838	ECUV1H101JCX	S.M.CAP	50V	100pF	
C1843	ECUV1H472KBX	S.M.CAP	50V	4.7nF	
C1845	ECUV1H560JCX	S.M.CAP	50V	56pF	
C1849	ECKC1H102J	CERAMIC	50V	1000pF	
C1851	ECUV1H470JCX	S.M.CAP	50V	47pF	
C1852	ECUV1H390JCX	S.M.CAP	50V	39pF	
C1853	ECUV1H390JCX	S.M.CAP	50V	39pF	
C1857	ECUV1H560JCX	S.M.CAP	50V	56pF	
C1859	ECUV1H560JCX	S.M.CAP	50V	56pF	
C1871	ECUV1H103KBX	S.M.CAP	50V	10nF	
C1879	ECUV1H560JCX	S.M.CAP	50V	56pF	
C1888	ECUV1H103KBX	S.M.CAP	50V	10nF	
C1891	ECUV1H102KBX	S.M.CAP	50V	1nF	
C1893	ECUV1H102KBX	S.M.CAP	50V	1nF	
C1894	ECUV1H102KBX	S.M.CAP	50V	1nF	
C1922	ECUV1H103KBX	S.M.CAP	50V	10nF	
C1925	ECUV1H103KBX	S.M.CAP	50V	10nF	
C1931	ECUV1H103KBX	S.M.CAP	50V	10nF	
C1941	ECUV1H103KBX	S.M.CAP	50V	10nF	
C1942	ECA1CM470GB	ELECT	16V	47µF	
C1961	ECUV1C104KBX	S.M.CAP	16V	0.10µF	
C1962	ECUV1C104KBX	S.M.CAP	16V	0.10µF	
C1963	ECUV1C104KBX	S.M.CAP	16V	0.10µF	
C1964	ECUV1C104KBX	S.M.CAP	16V	0.10µF	
C1971	ECUV1H104ZFX	S.M.CAP	50V	100nF	
C1972	ECA1CM470GB	ELECT	16V	47µF	
C1973	ECUV1H104ZFX	S.M.CAP	50V	100nF	
C1974	ECUV1H104ZFX	S.M.CAP	50V	100nF	
C1976	ECUV1H104ZFX	S.M.CAP	50V	100nF	
C1977	ECA0JM471GB	ELECT	6.3V	470pF	
C1981	ECUV1H104ZFX	S.M.CAP	50V	100nF	
C1982	ECUV1H101JCX	S.M.CAP	50V	100pF	
C2401	ECA1HM101GB	ELECT	50V	100pF	
C2402	ECUV1H393KBX	S.M.CAP	50V	39nF	
C2405	ECA1HM4R7GB	ELECT	50V	4.7µF	
C2406	ECA1HM4R7GB	ELECT	50V	4.7µF	
C2407	ECA1HM4R7GB	ELECT	50V	4.7µF	
C2408	ECA1HM4R7GB	ELECT	50V	4.7µF	
C2409	ECA1HM4R7GB	ELECT	50V	4.7µF	

Ref No.	Part No.	Description		
C2415	ECUV1H103ZFX	S.M.CAP	50V	10nF
C2416	ECUV1H562KBX	S.M.CAP	50V	5.6nF
C2418	ECQM1H104J	FILM	50V	100nF
C2420	ECUV1H104KBX	S.M.CAP	50V	100nF
C2421	ECA1EM101GB	ELECT	25V	1µF
C2422	ECA1EM101GB	ELECT	25V	1µF
C2423	ECUV1H104KBX	S.M.CAP	50V	100nF
C2424	ECA1CM220GB	ELECT	16V	22µF
C2425	ECUV1H103KBX	S.M.CAP	50V	10nF
C2426	ECUV1H101JCX	S.M.CAP	50V	100pF
C2429	ECUV1H101JCX	S.M.CAP	50V	100pF
C2432	ECUV1H561JCX	S.M.CAP	50V	560pF
C2433	ECUV1H561JCX	S.M.CAP	50V	560pF
C2434	ECUV1H561JCX	S.M.CAP	50V	560pF
C2435	ECUV1H561JCX	S.M.CAP	50V	560pF
C2436	ECUV1H561JCX	S.M.CAP	50V	560pF
C2437	ECA1HM100GB	ELECT	50V	10pF
C2438	ECA1HM010GB	ELECT	50V	1pF
C2439	ECA1HM010GB	ELECT	50V	1pF
C2440	ECA1HM100GB	ELECT	50V	10pF
C2441	ECUV1H393KBX	S.M.CAP	50V	39nF
C2442	ECUV1H393KBX	S.M.CAP	50V	39nF
C2443	ECUV1H050CCX	S.M.CAP	50V	5pF
C2444	ECUV1H393KBX	S.M.CAP	50V	39nF
C2445	ECEA1HN010UB	ELECT	50V	1µF
C2446	ECEA1HN010UB	ELECT	50V	1µF
C2447	ECA1HMR47GB	ELECT	50V	0.47µF
C2448	ECA1HMR47GB	ELECT	50V	0.47µF
C2449	ECA1HM100GB	ELECT	50V	10pF
C2450	ECUV1H222KBX	S.M.CAP	50V	2.2nF
C2451	ECA1HM010GB	ELECT	50V	1pF
C2454	ECA1HM010GB	ELECT	50V	1pF
C2455	ECA1HM010GB	ELECT	50V	1pF
C2456	ECA1HM330B	ELECT	50V	33pF
C2459	ECA1HM010GB	ELECT	50V	1pF
C2461	ECA1HM100GB	ELECT	50V	10pF
C2464	ECA1HMR22GB	ELECT	50V	0.22µF
C2467	ECA1HMR22GB	ELECT	50V	0.22µF
C2468	ECA1HM010GB	ELECT	50V	1pF
C2469	ECA1HM010GB	ELECT	50V	1pF
C2470	ECA1HM100GB	ELECT	50V	10pF
C2471	ECA1CM471GB	ELECT	16V	470pF
C2472	ECA1HM100GB	ELECT	50V	10pF
C2473	ECUV1H103ZFX	S.M.CAP	50V	10nF
C2474	ECUV1H103ZFX	S.M.CAP	50V	10nF
C2475	ECUV1H330JCX	S.M.CAP	50V	33pF
C2476	ECUV1H330JCX	S.M.CAP	50V	33pF
C2477	ECUV1H101JCX	S.M.CAP	50V	100pF
C2478	ECA1HM220GB	ELECT	50V	22pF
C2479	ECEA1HN010UB	ELECT	50V	1µF
C2480	ECEA1HN010UB	ELECT	50V	1µF
C2481	ECEA1HN010UB	ELECT	50V	1µF
C2482	ECEA1HN010UB	ELECT	50V	1µF
C2484	ECUV1H103KBX	S.M.CAP	50V	10nF
C2485	ECA1HMR22GB	ELECT	50V	0.22µF
C2486	ECUV1H103KBX	S.M.CAP	50V	10nF
C2487	ECA1HMR22GB	ELECT	50V	0.22µF
C2488	ECUV1H103KBX	S.M.CAP	50V	10nF
C2489	ECUV1H104ZFX	S.M.CAP	50V	100nF
C2490	ECEA1HU101	ELECT	50V	100µF
C2491	ECA1HM100GB	ELECT	50V	10pF
C2492	ECUV1H103KBX	S.M.CAP	50V	10nF
C2493	ECA1HMR22GB	ELECT	50V	0.22µF
C2494	ECA1HM4R7GB	ELECT	50V	4.7µF
C2495	ECA1HM100GB	ELECT	50V	10pF
C2496	ECUV1H101JCX	S.M.CAP	50V	100pF
C2497	ECA1HM100GB	ELECT	50V	10pF
C2498	ECUV1H101JCX	S.M.CAP	50V	100pF
C2499	ECA1HM100GB	ELECT	50V	10pF
C2501	TAC1114Z105A	CERAMIC		1µF
C2502	ECOS2GA101BB	ELECT	400V	100µF
C2504	ECKC3D471JB	CERAMIC	2KV	470pF

Ref No.	Part No.	Description		
C2505	ECKC2H103J	CERAMIC	50V	10nF
C2506	ECQM1H333J	FILM	50V	33nF
C2507	ECQM1H683J	FILM	50V	68nF
C2508	ECA1CM221GB	ELECT	16V	220pF
C2509	ECA1CM221GB	ELECT	16V	220pF
C2510	ECKCWS102MEBC	CERAMIC		1nF
C2512	ECA1CM102B	ELECT	16V	1nF
C2513	ECA1HM010GB	ELECT	50V	1pF
C2514	ECA1HM010GB	ELECT	50V	1pF
C2516	ECA1HM010GB	ELECT	50V	1pF
C2517	ECKC2H471J	CERAMIC	500V	470pF
C2518	ECA1EM101GB	ELECT	25V	1µF
C2520	ECEA1HU471	ELECT	50V	470µF
C2521	ECQM1H104J	FILM	50V	100nF
C2522	ECA1HM010GB	ELECT	50V	1pF
C2523	ECUV1H101JCX	S.M.CAP	50V	100pF
C2524	ECA1HM330B	ELECT	50V	33pF
C2525	ECUV1H103ZFX	S.M.CAP	50V	10nF
C2526	ECA1HM222E	ELECT	50V	2.2nF
C2527	ECUV1H222KBX	S.M.CAP	50V	2.2nF
C2528	ECA1HM222E	ELECT	50V	2.2nF
C2529	ECUV1H103ZFX	S.M.CAP	50V	10nF
C2531	ECQM1H474J	FILM	50V	470nF
C2532	ECA1HM010GB	ELECT	50V	1pF
C2533	ECUV1H101JCX	S.M.CAP	50V	100pF
C2534	ECA1HM330B	ELECT	50V	33pF
C2535	ECUV1H103ZFX	S.M.CAP	50V	10nF
C2536	ECA1HM010GB	ELECT	50V	1pF
C2537	ECUV1H222KBX	S.M.CAP	50V	2.2nF
C2538	ECA1HM010GB	ELECT	50V	1pF
C2539	ECUV1H103ZFX	S.M.CAP	50V	10nF
C2540	ECUV1H683ZFX	S.M.CAP	50V	68nF
C2541	ECQM1H474J	FILM	50V	470nF
C2542	ECUV1H332KBX	S.M.CAP	50V	3.3nF
C2543	ECUV1H332KBX	S.M.CAP	50V	3.3nF
C2544	ECUV1H223ZFX	S.M.CAP	50V	22nF
C2545	ECUV1H473ZFX	S.M.CAP	50V	47nF
C2546	ECA1CM221GB	ELECT	16V	220pF
C2547	ECA1HM100GB	ELECT	50V	10pF
C2548	ECA1HM100GB	ELECT	50V	10pF
C2549	ECA1HM100GB	ELECT	50V	10pF
C2550	ECA1HM100GB	ELECT	50V	10pF
C2551	ECA1CM221GB	ELECT	16V	220pF
C2552	ECA1HM010GB	ELECT	50V	1pF
C2553	ECA1HM010GB	ELECT	50V	1pF
C2554	ECUV1H104ZFX	S.M.CAP	50V	100nF
C2555	ECUV1H104ZFX	S.M.CAP	50V	100nF
C2556	ECA1HMR47GB	ELECT	50V	0.47µF
C2557	ECA1HM4R7GB	ELECT	50V	4.7µF
C2558	ECA1HMR47GB	ELECT	50V	0.47µF
C2559	ECA1HM4R7GB	ELECT	50V	4.7µF
C2560	ECUV1C154KBX	S.M.CAP	16V	0.15µF
C2561	ECA1HM3R3GB	ELECT	50V	3.3µF
C2562	ECUV1C154KBX	S.M.CAP	16V	0.15µF
C2563	ECUV1C154KBX	S.M.CAP	16V	0.15µF
C2564	ECA1HM3R3GB	ELECT	50V	3.3µF
C2565	ECUV1C154KBX	S.M.CAP	16V	0.15µF
C2566	ECA1HM4R7GB	ELECT	50V	4.7µF
C2567	ECA1HMR47GB	ELECT	50V	0.47µF
C2568	ECA1HM4R7GB	ELECT	50V	4.7µF
C2569	ECA1HMR47GB	ELECT	50V	0.47µF
C2570	ECUV1H104ZFX	S.M.CAP	50V	100nF
C2571	ECUV1H104ZFX	S.M.CAP	50V	100nF
C2572	ECA1HM470GB	ELECT	50V	47µF
C2573	ECQM1H474J	FILM	50V	470nF
C2574	ECUV1H681JCX	S.M.CAP	50V	680pF
C2575	ECA1HM010GB	ELECT	50V	1pF
C2576	ECA1HM010GB	ELECT	50V	1pF
C2577	ECA1CM221GB	ELECT	16V	220pF
C2578	ECA1HM2R2GB	ELECT	50V	2.2µF
C2579	ECUV1H103ZFX	S.M.CAP	50V	10nF
C2580	ECEA1HN010UB	ELECT	50V	1µF

Ref No.	Part No.	Description		
C2581	ECA1HM100GB	ELECT	50V	10pF
C2582	ECUV1H103ZFX	S.M.CAP	50V	10nF
C2583	ECA1CM221GB	ELECT	16V	220pF
C2584	ECA1HM010GB	ELECT	50V	1pF
C2585	ECUV1H333KBX	S.M.CAP	50V	33nF
C2586	ECUV1H152JCX	S.M.CAP	50V	1.5pF
C2587	ECUV1H333KBX	S.M.CAP	50V	33nF
C2588	ECA1CM221GB	ELECT	16V	220pF
C2589	ECUV1H330JCX	S.M.CAP	50V	33pF
C2590	ECUV1H330JCX	S.M.CAP	50V	33pF
C2591	ECEA1HN010UB	ELECT	50V	1µF
C2592	ECA1HM010GB	ELECT	50V	1pF
C2593	ECEA1HN010UB	ELECT	50V	1µF
C2594	ECEA1HN010UB	ELECT	50V	1µF
C2595	ECEA1HN010UB	ELECT	50V	1µF
C2596	ECUV1H103ZFX	S.M.CAP	50V	10nF
C2597	ECA1CM471GB	ELECT	16V	470pF
C2598	ECA1HM010GB	ELECT	50V	1pF
C2599	ECA1HM010GB	ELECT	50V	1pF
C2801	ECA1HM010GB	ELECT	50V	1pF
C2802	ECA1HM010GB	ELECT	50V	1pF
C2803	ECA1HM010GB	ELECT	50V	1pF
C2804	ECA1HM010GB	ELECT	50V	1pF
C2805	ECA1CM100GB	ELECT	16V	10pF
C2806	ECA1HM010GB	ELECT	50V	1pF
C2807	ECUV1H222KBX	S.M.CAP	50V	2.2nF
C2808	ECA1HM010GB	ELECT	50V	1pF
C2809	ECUV1H222KBX	S.M.CAP	50V	2.2nF
C2810	ECA1HM010GB	ELECT	50V	1pF
C2811	ECUV1H222KBX	S.M.CAP	50V	2.2nF
C2812	ECA1HM010GB	ELECT	50V	1pF
C2813	ECUV1H222KBX	S.M.CAP	50V	2.2nF
C2814	ECA1HM100GB	ELECT	50V	10pF
C2815	ECA1CM471GB	ELECT	16V	470pF
C3101	ECUV1H030CCX	S.M.CAP	50V	30pF
C3102	ECUV1H103ZFX	S.M.CAP	50V	10nF
C3103	ECA1HM100GB	ELECT	50V	10pF
C3122	ECUV1H102KBX	S.M.CAP	50V	1nF
C3124	ECUV1H471JCX	S.M.CAP	50V	470pF
C3131	ECKC2H471J	CERAMIC	500V	470pF
C3134	ECA1HM101GB	ELECT	50V	100pF
C3136	ECKC2H471J	CERAMIC	500V	470pF
C3139	ECA1HM101GB	ELECT	50V	100pF
C3141	ECA1CM471GB	ELECT	16V	470pF
C3143	ECA1CM100GB	ELECT	16V	10pF
C3144	ECA1CM470GB	ELECT	16V	47µF
C3146	ECEA2EU220	ELECT	250V	22µF
C3152	ECEA2EU220	ELECT	250V	22µF
C3153	ECA1VM101GB	ELECT	35V	100pF
C3167	ECUV1H100DCX	S.M.CAP	50V	10pF
C3168	ECUV1H103ZFX	S.M.CAP	50V	10nF
C3169	ECA1CM100GB	ELECT	16V	10pF
C3177	ECUV1H150JCX	S.M.CAP	50V	15pF
C3178	ECUV1H103ZFX	S.M.CAP	50V	10nF
C3179	ECA1CM100GB	ELECT	16V	10pF
C3187	ECUV1H270JCX	S.M.CAP	50V	27pF
C3188	ECUV1H103ZFX	S.M.CAP	50V	10nF
C3189	ECA1CM100GB	ELECT	16V	10pF
C3356	ECA1CM220GB	ELECT	16V	22µF
C3357	ECUV1H104ZFX	S.M.CAP	50V	100nF
C3362	TACA1103P2KV	I.C.		
C3363	TACA1103P2KV	I.C.		
C3366	ECEA2EU220	ELECT	250V	22µF
C3367	ECQM2104KZ	FILM	250V	100nF
C3369	ECA1HM010GB	ELECT	50V	1pF
C3371	ECUV1H150JCX	S.M.CAP	50V	15pF
C3373	ECUV1H104ZFX	S.M.CAP	50V	100nF
C3377	ECUV1H681JCX	S.M.CAP	50V	680pF
C3383	ECUV1H104ZFX	S.M.CAP	50V	100nF
C3387	ECUV1H681JCX	S.M.CAP	50V	680pF
C3392	ECA1CM471GB	ELECT	16V	470pF
C3393	ECUV1H104ZFX	S.M.CAP	50V	100nF

Ref No.	Part No.	Description		
C3397	ECUV1H681JCX	S.M.CAP	50V	680pF
C3398	ECKC1H102J	CERAMIC	50V	1000pF
C4701	ECUV1H151JCX	S.M.CAP	50V	150pF
C4702	ECUV1H331JCX	S.M.CAP	50V	330pF
C4703	ECEA1HKAR47	ELECT	50V	0.47µF
C4704	ECUV1H104ZFX	S.M.CAP	50V	100nF
C4705	ECUV1H104ZFX	S.M.CAP	50V	100nF
C4706	ECUV1H104ZFX	S.M.CAP	50V	100nF
C4707	ECUV1H104ZFX	S.M.CAP	50V	100nF
C4708	ECEA1CKA100	ELECT	16V	10µF
C4709	ECUV1H104ZFX	S.M.CAP	50V	100nF
C4710	ECEA1CKA100	ELECT	16V	10µF
C4711	ECUV1H390JPX	S.M.CAP	50V	39pF
C4712	ECUV1H150JCX	S.M.CAP	50V	15pF
C4713	ECUV1H104ZFX	S.M.CAP	50V	100nF
C4714	ECEA1EKA100	ELECT	25V	10µF
C4715	ECUV1H104ZFX	S.M.CAP	50V	100nF
C4716	ECEA1CKA100	ELECT	16V	10µF
C4717	ECUV1H683ZFX	S.M.CAP	50V	68nF
C4718	ECUV1H102KBX	S.M.CAP	50V	1nF
C4719	ECEA1HKAR47	ELECT	50V	0.47µF
C4720	ECUV1H104ZFX	S.M.CAP	50V	100nF
C4721	ECEA1HKA2R2	ELECT	50V	2.2µF
C4722	ECUV1H104ZFX	S.M.CAP	50V	100nF
C4723	ECUV1H104ZFX	S.M.CAP	50V	100nF
C4724	ECUV1H104ZFX	S.M.CAP	50V	100nF
C4725	ECUV1H104ZFX	S.M.CAP	50V	100nF
C4726	ECEA1CKA470	ELECT	16V	47µF
C4727	ECUV1H104ZFX	S.M.CAP	50V	100nF
C4728	ECEA1CKA100	ELECT	16V	10µF
C4733	ECUV1H270JPX	S.M.CAP	50V	27pF
C4735	ECUV1H104ZFX	S.M.CAP	50V	100nF
C4736	ECUV1H104ZFX	S.M.CAP	50V	100nF
C4737	ECUV1H104ZFX	S.M.CAP	50V	100nF
C4738	ECUV1H104ZFX	S.M.CAP	50V	100nF
C4739	ECUV1H104ZFX	S.M.CAP	50V	100nF
C4740	ECUV1H104ZFX	S.M.CAP	50V	100nF
C4742	ECUV1H100DCX	S.M.CAP	50V	10pF
C4743	ECUV1H100DCX	S.M.CAP	50V	10pF
C4745	ECUV1H102KBX	S.M.CAP	50V	1nF
C4746	ECUV1H104ZFX	S.M.CAP	50V	100nF
C4747	ECUV1H102KBX	S.M.CAP	50V	1nF
C4748	ECUV1H102KBX	S.M.CAP	50V	1nF
C4749	ECUV1H102KBX	S.M.CAP	50V	1nF
C4790	ECEA1HKA010	ELECT	50V	1µF
C6101	ECEA1HU471	ELECT	50V	470µF
C6102	ECQM1H334J	FILM	50V	330nF
C6103	ECQM1H104J	FILM	50V	100nF
C6104	ECA0JM222GB	ELECT	6.3V	2.2nF
C6106	ECEA1HU101	ELECT	50V	100µF
C6301	ECA1CM470GB	ELECT	16V	47µF
C6303	ECUV1H103ZFX	S.M.CAP	50V	10nF
C6401	ECA1HM101GB	ELECT	50V	100pF
C6402	ECA1HM101GB	ELECT	50V	100pF
C6403	ECUV1H103ZFX	S.M.CAP	50V	10nF
C6406	ECA1HM4R7GB	ELECT	50V	4.7µF
C6407	ECUV1H102KBX	S.M.CAP	50V	1nF
C6408	ECA1HM4R7GB	ELECT	50V	4.7µF
C6409	ECUV1H561JCX	S.M.CAP	50V	560pF
C6410	ECUV1H561JCX	S.M.CAP	50V	560pF
C6417	ECA1CM471GB	ELECT	16V	470pF
C6418	ECUV1H103ZFX	S.M.CAP	50V	10nF
C6436	ECA1HM4R7GB	ELECT	50V	4.7µF
C6437	ECUV1H102KBX	S.M.CAP	50V	1nF
C6438	ECA1HM4R7GB	ELECT	50V	4.7µF
C6447	ECA1CM471GB	ELECT	16V	470pF
C6448	ECUV1H103ZFX	S.M.CAP	50V	10nF
C6491	ECUV1H271JCX	S.M.CAP	50V	270pF
C6591	ECUV1H271JCX	S.M.CAP	50V	270pF
C6811	ECKCNS332J	CERAMIC	1.2KV	3.3nF
C6812	ECQU2A154MN	FILM	250V	150nF

Ref No.	Part No.	Description
C6815	ECQU2A224MN	FILM 250V 220nF
DIODES		
D206	MA4300	DIODE
D465	MA165TA5	DIODE 1SS133T-77
D466	MA165TA5	DIODE 1SS133T-77
D467	MA165TA5	DIODE 1SS133T-77
D468	MA165TA5	DIODE 1SS133T-77
D471	MA700TA5	DIODE
D481	MA700TA5	DIODE
D491	MA167TA5	DIODE
D507	MA723TA5	DIODE
D508	MA723TA5	DIODE
D521	MA170	DIODE
D526	MA165TA5	DIODE 1SS133T-77
D527	EU02	DIODE
D536	ERB0615	DIODE TYPD0753VAG
D537	TVSRU2AM	DIODE
D544	TVSRC2V1	DIODE
D547	AU02V0	DIODE
D548	MA165TA5	DIODE 1SS133T-77
D549	MA167TA5	DIODE
D557	EU02	DIODE
D561	ERA15-02V3	DIODE
D562	MA165TA5	DIODE 1SS133T-77
D563	MA165TA5	DIODE 1SS133T-77
D564	MTZJ33B	DIODE
D566	MA2082ALFS	DIODE
D567	MTZJT776.2B	DIODE
D568	MA2100LFS	DIODE
D569	MA2082ALFS	DIODE
D591	MTZJT7739D	DIODE
D613	RBV-608LF-B	DIODE
D622	MA171TA5	DIODE
D624	BYT56K15/10	DIODE
D630	MA165TA5	DIODE 1SS133T-77
D636	MA167TA5	DIODE
D651	RG4CLFL1	DIODE
D656	EU02	DIODE
D661	ERD32-02L7	DIODE
D671	ERD32-02L7	DIODE
D674	MTZJT-7712C	DIODE
D678	MTZJT772.7B	DIODE
D681	EU02	DIODE
D686	RU4AMLF-M1	DIODE
D1019	PMLL5242B	DIODE
D1020	PMLL5242B	DIODE
D1023	PMLL5242B	DIODE
D1024	PMLL5242B	DIODE
D1033	PMLL5242B	DIODE
D1034	PMLL5242B	DIODE
D1036	PMLL5242B	DIODE
D1038	PMLL5242B	DIODE
D1121	PMLL5242B	DIODE
D1123	PMLL5242B	DIODE
D1156	PMLL5242B	DIODE
D1158	PMLL5242B	DIODE
D1172	PMLL5242B	DIODE
D1221	PMLL5232B	DIODE
D1222	PMLL5232B	DIODE
D1270	PMLL5242B	DIODE
D1273	PMLL5242B	DIODE
D1282	PMLL5242B	DIODE
D1284	PMLL5242B	DIODE
D1381	PMLL5239B	DIODE
D1382	RLS72TE-11	DIODE OR PMLL4148
D1601	RLS72TE-11	DIODE OR PMLL4148
D1614	RLS72TE-11	DIODE OR PMLL4148
D1617	RLS72TE-11	DIODE OR PMLL4148
D1623	RLS72TE-11	DIODE OR PMLL4148

Ref No.	Part No.	Description
D1624	RLS72TE-11	DIODE OR PMLL4148
D1672	RLS72TE-11	DIODE OR PMLL4148
D1681	RLS72TE-11	DIODE OR PMLL4148
D1682	RLS72TE-11	DIODE OR PMLL4148
D1717	RLS72TE-11	DIODE OR PMLL4148
D1941	PMLL5232B	DIODE
D2421	1SS355TE-17	DIODE
D2422	1SS355TE-17	DIODE
D2480	1SS355TE-17	DIODE
D2502	EG01CV0	DIODE
D2503	EU02	DIODE
D2504	TVSEH1V0	DIODE
D2505	MA4075	DIODE
D2506	EU02	DIODE
D2507	EU02	DIODE
D2510	EU02	DIODE
D2511	RU4AMLF-M1	DIODE
D2512	1SS355TE-17	DIODE
D2513	1SS254T-77	DIODE
D2514	1SS355TE-17	DIODE
D2515	1SS355TE-17	DIODE
D2517	1SS254T-77	DIODE
D2518	1SS254T-77	DIODE
D2519	1SS254T-77	DIODE
D2520	1SS254T-77	DIODE
D2520	1SS355TE-17	DIODE
D2521	1SS254T-77	DIODE
D2522	1SS254T-77	DIODE
D2523	1SS254T-77	DIODE
D2524	MA4120	DIODE
D2525	MA4120	DIODE
D2526	MA4120	DIODE
D2527	MA4120	DIODE
D2528	UDZTE-1712B	DIODE
D2529	1SS355TE-17	DIODE
D2530	1SS355TE-17	DIODE
D2531	1SS355TE-17	DIODE
D2801	RLS73TE-11	COIL
D3126	RLS72TE-11	DIODE OR PMLL4148
D3127	RLS72TE-11	DIODE OR PMLL4148
D3133	RLS72TE-11	DIODE OR PMLL4148
D3138	RLS72TE-11	DIODE OR PMLL4148
D3368	RLS72TE-11	DIODE OR PMLL4148
D3372	MA165TA5	DIODE 1SS133T-77
D3373	RLS72TE-11	DIODE OR PMLL4148
D3374	RLS72TE-11	DIODE OR PMLL4148
D3377	RLS72TE-11	DIODE OR PMLL4148
D3382	MA165TA5	DIODE 1SS133T-77
D3383	RLS72TE-11	DIODE OR PMLL4148
D3384	RLS72TE-11	DIODE OR PMLL4148
D3387	RLS72TE-11	DIODE OR PMLL4148
D3391	MA165TA5	DIODE 1SS133T-77
D3392	MA165TA5	DIODE 1SS133T-77
D3393	RLS72TE-11	DIODE OR PMLL4148
D3394	RLS72TE-11	DIODE OR PMLL4148
D3397	RLS72TE-11	DIODE OR PMLL4148
D6101	TVSS1WBS20	DIODE
D6103	RLS72TE-11	DIODE OR PMLL4148
D6106	RLS72TE-11	DIODE OR PMLL4148
D6301	LN81RPHL	DIODE
D6381	RLS72TE-11	DIODE OR PMLL4148
D6382	RLS72TE-11	DIODE OR PMLL4148
D6391	RLS72TE-11	DIODE OR PMLL4148
D6392	RLS72TE-11	DIODE OR PMLL4148
D6491	RLS72TE-11	DIODE OR PMLL4148
D6492	RLS72TE-11	DIODE OR PMLL4148
D6591	RLS72TE-11	DIODE OR PMLL4148
D6592	RLS72TE-11	DIODE OR PMLL4148

Ref No.	Part No.	Description			
FUSES					
F547	TR5-T2000	FUSE			▲
F656	TR5-T1250	FUSE			▲
F661	TR5-T2000	FUSE			▲
F671	TR5-T2000	FUSE			▲
F6811	2153.15H	FUSE			▲
F68111	EYF52BC	FUSE HOLDER			
F68112	EYF52BC	FUSE HOLDER			
SOCKETS					
H1871	832AG11D-ESL	I.C.SOCKET			
TERMINALS AND LINKS					
JC1	ERJ6GEY0R00	S.M.CARB	0.1W	5%	Ω
JC1001	ERJ8GEY0R00	S.M.CAR	.125W	5%	Ω
JC1002	ERJ8GEY0R00	S.M.CAR	.125W	5%	Ω
JC1003	ERJ8GEY0R00	S.M.CAR	.125W	5%	Ω
JC1004	ERJ8GEY0R00	S.M.CAR	.125W	5%	Ω
JC1005	ERJ6GEY0R00	S.M.CARB	0.1W	5%	Ω
JC1006	ERJ6GEY0R00	S.M.CARB	0.1W	5%	Ω
JC1007	ERJ8GEY0R00	S.M.CAR	.125W	5%	Ω
JC1008	ERJ8GEY0R00	S.M.CAR	.125W	5%	Ω
JC1009	ERJ8GEY0R00	S.M.CAR	.125W	5%	Ω
JC1010	ERJ8GEY0R00	S.M.CAR	.125W	5%	Ω
JC1011	ERJ8GEY0R00	S.M.CAR	.125W	5%	Ω
JC1012	ERJ6GEY0R00	S.M.CARB	0.1W	5%	Ω
JC1013	ERJ6GEY0R00	S.M.CARB	0.1W	5%	Ω
JC1014	ERJ8GEY0R00	S.M.CAR	.125W	5%	Ω
JC1015	ERJ6GEY0R00	S.M.CARB	0.1W	5%	Ω
JC1016	ERJ8GEY0R00	S.M.CAR	.125W	5%	Ω
JC1017	ERJ8GEY0R00	S.M.CAR	.125W	5%	Ω
JC1018	ERJ8GEY0R00	S.M.CAR	.125W	5%	Ω
JC1019	ERJ6GEY0R00	S.M.CARB	0.1W	5%	Ω
JC1020	ERJ8GEY0R00	S.M.CAR	.125W	5%	Ω
JC1021	ERJ8GEY0R00	S.M.CAR	.125W	5%	Ω
JC1022	ERJ8GEY0R00	S.M.CAR	.125W	5%	Ω
JC1023	ERJ8GEY0R00	S.M.CAR	.125W	5%	Ω
JC1024	ERJ6GEY0R00	S.M.CARB	0.1W	5%	Ω
JC1025	ERJ8GEY0R00	S.M.CAR	.125W	5%	Ω
JC1026	ERJ8GEY0R00	S.M.CAR	.125W	5%	Ω
JC1027	ERJ6GEY0R00	S.M.CARB	0.1W	5%	Ω
JC1029	ERJ8GEY0R00	S.M.CAR	.125W	5%	Ω
JC1030	ERJ6GEY0R00	S.M.CARB	0.1W	5%	Ω
JC1031	ERJ6GEY0R00	S.M.CARB	0.1W	5%	Ω
JC1032	ERJ6GEY0R00	S.M.CARB	0.1W	5%	Ω
JC1033	ERJ8GEY0R00	S.M.CAR	.125W	5%	Ω
JC1034	ERJ8GEY0R00	S.M.CAR	.125W	5%	Ω
JC1035	ERJ6GEY0R00	S.M.CARB	0.1W	5%	Ω
JC1036	ERJ8GEY0R00	S.M.CAR	.125W	5%	Ω
JC1037	ERJ8GEY0R00	S.M.CAR	.125W	5%	Ω
JC1040	ERJ8GEY0R00	S.M.CAR	.125W	5%	Ω
JC1041	ERJ8GEY0R00	S.M.CAR	.125W	5%	Ω
JC1042	ERJ8GEY0R00	S.M.CAR	.125W	5%	Ω
JC1043	ERJ8GEY0R00	S.M.CAR	.125W	5%	Ω
JC1044	ERJ8GEY0R00	S.M.CAR	.125W	5%	Ω
JC1045	ERJ6GEY0R00	S.M.CARB	0.1W	5%	Ω
JC1047	ERJ8GEY0R00	S.M.CAR	.125W	5%	Ω
JC1048	ERJ6GEY0R00	S.M.CARB	0.1W	5%	Ω
JC1049	ERJ8GEY0R00	S.M.CAR	.125W	5%	Ω
JC1050	ERJ8GEY0R00	S.M.CAR	.125W	5%	Ω
JC1051	ERJ6GEY0R00	S.M.CARB	0.1W	5%	Ω
JC1052	ERJ8GEY0R00	S.M.CAR	.125W	5%	Ω
JC1053	ERJ8GEY0R00	S.M.CAR	.125W	5%	Ω
JC1054	ERJ8GEY0R00	S.M.CAR	.125W	5%	Ω
JC1055	ERJ6GEY0R00	S.M.CARB	0.1W	5%	Ω
JC1056	ERJ6GEY0R00	S.M.CARB	0.1W	5%	Ω

Ref No.	Part No.	Description			
JC1057	ERJ6GEY0R00	S.M.CARB	0.1W	5%	Ω
JC1058	ERJ8GEY0R00	S.M.CAR	.125W	5%	Ω
JC1059	ERJ8GEY0R00	S.M.CAR	.125W	5%	Ω
JC1060	ERJ6GEY0R00	S.M.CARB	0.1W	5%	Ω
JC1061	ERJ8GEY0R00	S.M.CAR	.125W	5%	Ω
JC1062	ERJ8GEY0R00	S.M.CAR	.125W	5%	Ω
JC1064	ERJ6GEY0R00	S.M.CARB	0.1W	5%	Ω
JC1065	ERJ8GEY0R00	S.M.CAR	.125W	5%	Ω
JC1066	ERJ6GEY0R00	S.M.CARB	0.1W	5%	Ω
JC1067	ERJ6GEY0R00	S.M.CARB	0.1W	5%	Ω
JC1068	ERJ6GEY0R00	S.M.CARB	0.1W	5%	Ω
JC1069	ERJ8GEY0R00	S.M.CAR	.125W	5%	Ω
JC1070	ERJ6GEY0R00	S.M.CARB	0.1W	5%	Ω
JC1071	ERJ6GEY0R00	S.M.CARB	0.1W	5%	Ω
JC1072	ERJ6GEY0R00	S.M.CARB	0.1W	5%	Ω
JC1073	ERJ8GEY0R00	S.M.CAR	.125W	5%	Ω
JC1074	ERJ6GEY0R00	S.M.CARB	0.1W	5%	Ω
JC1075	ERJ6GEY0R00	S.M.CARB	0.1W	5%	Ω
JC1076	ERJ6GEY0R00	S.M.CARB	0.1W	5%	Ω
JC1077	ERJ8GEY0R00	S.M.CAR	.125W	5%	Ω
JC1078	ERJ6GEY0R00	S.M.CARB	0.1W	5%	Ω
JC1079	ERJ8GEY0R00	S.M.CAR	.125W	5%	Ω
JC1080	ERJ8GEY0R00	S.M.CAR	.125W	5%	Ω
JC1081	ERJ8GEY0R00	S.M.CAR	.125W	5%	Ω
JC1082	ERJ8GEY0R00	S.M.CAR	.125W	5%	Ω
JC1083	ERJ8GEY0R00	S.M.CAR	.125W	5%	Ω
JC1084	ERJ6GEY0R00	S.M.CARB	0.1W	5%	Ω
JC1085	ERJ6GEY0R00	S.M.CARB	0.1W	5%	Ω
JC1086	ERJ6GEY0R00	S.M.CARB	0.1W	5%	Ω
JC1087	ERJ6GEY0R00	S.M.CARB	0.1W	5%	Ω
JC1088	ERJ6GEY0R00	S.M.CARB	0.1W	5%	Ω
JC1089	ERJ8GEY0R00	S.M.CAR	.125W	5%	Ω
JC1090	ERJ6GEY0R00	S.M.CARB	0.1W	5%	Ω
JC1091	ERJ6GEY0R00	S.M.CARB	0.1W	5%	Ω
JC1093	ERJ8GEY0R00	S.M.CAR	.125W	5%	Ω
JC1094	ERJ8GEY0R00	S.M.CAR	.125W	5%	Ω
JC1095	ERJ8GEY0R00	S.M.CAR	.125W	5%	Ω
JC1096	ERJ6GEY0R00	S.M.CARB	0.1W	5%	Ω
JC1097	ERJ6GEY0R00	S.M.CARB	0.1W	5%	Ω
JC1098	ERJ8GEY0R00	S.M.CAR	.125W	5%	Ω
JC1099	ERJ8GEY0R00	S.M.CAR	.125W	5%	Ω
JC1100	ERJ8GEY0R00	S.M.CAR	.125W	5%	Ω
JC1101	ERJ8GEY0R00	S.M.CAR	.125W	5%	Ω
JC1102	ERJ8GEY0R00	S.M.CAR	.125W	5%	Ω
JC1103	ERJ6GEY0R00	S.M.CARB	0.1W	5%	Ω
JC1104	ERJ8GEY0R00	S.M.CAR	.125W	5%	Ω
JC1105	ERJ8GEY0R00	S.M.CAR	.125W	5%	Ω
JC1106	ERJ8GEY0R00	S.M.CAR	.125W	5%	Ω
JC1107	ERJ8GEY0R00	S.M.CAR	.125W	5%	Ω
JC1108	ERJ8GEY0R00	S.M.CAR	.125W	5%	Ω
JC1109	ERJ6GEY0R00	S.M.CARB	0.1W	5%	Ω
JC1111	ERJ6GEY0R00	S.M.CARB	0.1W	5%	Ω
JC1112	ERJ6GEY0R00	S.M.CARB	0.1W	5%	Ω
JC1113	ERJ6GEY0R00	S.M.CARB	0.1W	5%	Ω
JC1114	ERJ8GEY0R00	S.M.CAR	.125W	5%	Ω
JC1115	ERJ6GEY0R00	S.M.CARB	0.1W	5%	Ω
JC1116	ERJ6GEY0R00	S.M.CARB	0.1W	5%	Ω
JC1117	ERJ6GEY0R00	S.M.CARB	0.1W	5%	Ω
JC1119	ERJ6GEY0R00	S.M.CARB	0.1W	5%	Ω
JC1121	ERJ6GEY0R00	S.M.CARB	0.1W	5%	Ω
JC1122	ERJ6GEY0R00	S.M.CARB	0.1W	5%	Ω
JC1123	ERJ6GEY0R00	S.M.CARB	0.1W	5%	Ω
JC1124	ERJ6GEY0R00	S.M.CARB	0.1W	5%	Ω
JC1125	ERJ6GEY0R00	S.M.CARB	0.1W	5%	Ω
JC2	ERJ6GEY0R00	S.M.CARB	0.1W	5%	Ω
JC3	ERJ6GEY0R00	S.M.CARB	0.1W	5%	Ω
JK2501	TJB8E013	6 PIN PUSH TERMINAL			
JK2502	TJB8E015	RCA TERMINAL (3P)			
JK2503	TJB8E014	RCA TERMINAL (2P)			
JK6401	TJB16656	A.V. TERMINAL			
J1	ERDS2TY0T	CARBON	0.25W	5%	Ω
J2	ERDS2TY0T	CARBON	0.25W	5%	Ω

Ref No.	Part No.	Description
J2	ERJ6GEY0R00	S.M.CARB 0.1W 5% 0Ω
J12	EXCELSA39V	COIL
J23	EXCELSA39V	COIL
J204	EXCELSA35T	COIL
COILS		
L204	ELER220KA	COIL
L206	EXCELSA35T	COIL
L231	EXCELSA24T	COIL
L507	TLT331K991R	COIL
L511	297-23477	COIL
L538	297-23293	COIL
L541	ELH5L7002	COIL
L542	ELC08D055	COIL
L554	ELER220KA	COIL
L594	297-017696	COIL
L624	EXCELSA35T	COIL
L626	EXCELSR35S	COIL
L650	EXCELDR35C	COIL
L661	EXCELDR35V	COIL
L671	EXCELDR35V	COIL
L686	EXCELSA35T	COIL
L1037	TSC925-4	CHOKE
L1301	EXCELDR35V	COIL
L1303	EXCELDR35V	COIL
L1351	ELEV4R7KA	COIL
L1413	ELEV6R8KA	COIL
L1601	ELEV4R7KA	COIL
L1606	EXCELDR35V	COIL
L1611	ELEV4R7KA	COIL
L1619	EXCELDR35V	COIL
L1622	ELEV4R7KA	COIL
L1634	EXCEMT101BT	COIL
L1644	EXCEMT101BT	COIL
L1652	ELEV4R7KA	COIL
L1654	EXCEMT101BT	COIL
L1687	ELEMV1R5MA	COIL
L1691	EXCEMT101BT	COIL
L1692	EXCEMT101BT	COIL
L1693	EXCEMT101BT	COIL
L1694	EXCEMT101BT	COIL
L1701	ELEV4R7KA	COIL
L1714	EXCELDR35V	COIL
L1751	EXCELDR35V	COIL
L1801	ELEV4R7KA	COIL
L1837	EXCELDR35V	COIL
L1845	ELEV3R3KA	COIL
L1857	ELEV3R3KA	COIL
L1859	ELEV3R3KA	COIL
L1871	EXCELDR35V	COIL
L1878	ELEV3R3KA	COIL
L1888	ELEV4R7KA	COIL
L1931	ELEV4R7KA	COIL
L1941	EXCELDR35V	COIL
L1972	EXCELDR35V	COIL
L1974	EXCELDR35V	COIL
L1977	EXCELDR35V	COIL
L2501	EXCELSA35T	COIL
L2502	EXCELSA35T	COIL
L2503	EXCELSA35T	COIL
L2504	EXCELSA35T	COIL
L2505	5770206400	COIL
L2506	5770206400	COIL
L2507	5770206400	COIL
L2508	ELESN100KA	COIL
L2509	ELESN100KA	COIL
L2510	ELESN100KA	COIL
L2511	EXCELSA35T	COIL
L2512	EXCELSA35T	COIL
L2513	EXCELSA35T	COIL

Ref No.	Part No.	Description
L2514	5770206400	COIL
L3161	SDL-4101	COIL
L3171	SDL-4101	COIL
L3181	SDL-4101	COIL
L4701	TLTR33K991R	COIL
L4703	TLTR39K991R	COIL
L4704	TLT022K991R	COIL
L4705	EIV7EN200B	COIL
L4706	EIV7EN201B	COIL
L4707	TLT100K991R	COIL
L4709	TLT181K991R	COIL
L6403	ELEBT6R8KA	COIL
L6404	ELEBT6R8KA	COIL
L6417	ELEBT6R8KA	COIL
L6447	ELEBT6R8KA	COIL
L6811	ELF18D424F	COIL
L6812	ELF18D424F	COIL
CONTROLS		
P633	EVMEASA00B52	CONTROL 500Ω
P3362	RH092GDJ6J	VARIABLE RESISTOR
P3368	EVN65UA00B24	CONTROL 20KΩ
P4701	EVNDXAA03B53	CONTROL 5KΩ
TRANSISTORS		
Q463	BC557B	TRANSISTOR
Q465	BC547B	TRANSISTOR
Q494	BC547B	TRANSISTOR
Q496	BC547B	TRANSISTOR
Q497	BC557B	TRANSISTOR
Q498	BC547B	TRANSISTOR
Q506	2SK301TA	TRANSISTOR
Q526	2SD836-AL	TRANSISTOR
Q534	BU2508AXRL	TRANSISTOR
Q591	BC557B	TRANSISTOR
Q592	BC557B	TRANSISTOR
Q593	BC547B	TRANSISTOR
Q594	2SD1265A	TRANSISTOR
Q624	2SK1118LB	TRANSISTOR
Q651	TFD312SOF632	DIODE
Q674	BUZ71AF1	TRANSISTOR
Q681	BC557B	TRANSISTOR
Q682	2SA1535LB	TRANSISTOR
Q1123	BC847B	TRANSISTOR OR 2SD601ATX
Q1163	BC847B	TRANSISTOR OR 2SD601ATX
Q1167	BC857B	TRANSISTOR OR 2SB709ATX
Q1172	BC847B	TRANSISTOR OR 2SD601ATX
Q1182	BC847B	TRANSISTOR OR 2SD601ATX
Q1192	BC847B	TRANSISTOR OR 2SD601ATX
Q1221	BC847B	TRANSISTOR OR 2SD601ATX
Q1222	BC847B	TRANSISTOR OR 2SD601ATX
Q1382	BC857B	TRANSISTOR OR 2SB709ATX
Q1466	BC860B	TRANSISTOR
Q1476	BC860B	TRANSISTOR
Q1486	BC860B	TRANSISTOR
Q1496	BC860B	TRANSISTOR
Q1612	BC847B	TRANSISTOR OR 2SD601ATX
Q1631	BC847B	TRANSISTOR OR 2SD601ATX
Q1633	BC847B	TRANSISTOR OR 2SD601ATX
Q1636	BC857B	TRANSISTOR OR 2SB709ATX
Q1641	BC847B	TRANSISTOR OR 2SD601ATX
Q1643	BC847B	TRANSISTOR OR 2SD601ATX
Q1646	BC857B	TRANSISTOR OR 2SB709ATX
Q1651	BC847B	TRANSISTOR OR 2SD601ATX
Q1653	BC847B	TRANSISTOR OR 2SD601ATX
Q1656	BC857B	TRANSISTOR OR 2SB709ATX
Q1663	BC847B	TRANSISTOR OR 2SD601ATX
Q1664	BC847B	TRANSISTOR OR 2SD601ATX

Ref No.	Part No.	Description
Q1667	BC847B	TRANSISTOR OR 2SD601ATX
Q1673	BC847B	TRANSISTOR OR 2SD601ATX
Q1812	BC847B	TRANSISTOR OR 2SD601ATX
Q1816	BC847B	TRANSISTOR OR 2SD601ATX
Q1822	BC847B	TRANSISTOR OR 2SD601ATX
Q1824	BC847B	TRANSISTOR OR 2SD601ATX
Q1827	BC857B	TRANSISTOR OR 2SB709ATX
Q1831	BC847B	TRANSISTOR OR 2SD601ATX
Q2480	BC847B	TRANSISTOR OR 2SD601ATX
Q2501	BC557B	TRANSISTOR
Q2502	2SA684R	TRANSISTOR
Q2503	BC847B	TRANSISTOR OR 2SD601ATX
Q2504	BC847B	TRANSISTOR OR 2SD601ATX
Q2505	BC857B	TRANSISTOR OR 2SB709ATX
Q2506	BC847B	TRANSISTOR OR 2SD601ATX
Q2507	BC847B	TRANSISTOR OR 2SD601ATX
Q2508	BC857B	TRANSISTOR OR 2SB709ATX
Q2509	BC847B	TRANSISTOR OR 2SD601ATX
Q2510	BC857B	TRANSISTOR OR 2SB709ATX
Q2511	BC847B	TRANSISTOR OR 2SD601ATX
Q2512	BC857B	TRANSISTOR OR 2SB709ATX
Q2513	BC847B	TRANSISTOR OR 2SD601ATX
Q2514	BC847B	TRANSISTOR OR 2SD601ATX
Q2515	BC857B	TRANSISTOR OR 2SB709ATX
Q2516	BC847B	TRANSISTOR OR 2SD601ATX
Q2518	BC847B	TRANSISTOR OR 2SD601ATX
Q2801	BC847B	TRANSISTOR OR 2SD601ATX
Q3108	BC847B	TRANSISTOR OR 2SD601ATX
Q3109	BC847B	TRANSISTOR OR 2SD601ATX
Q3111	BC857B	TRANSISTOR OR 2SB709ATX
Q3122	BC847B	TRANSISTOR OR 2SD601ATX
Q3126	BC847B	TRANSISTOR OR 2SD601ATX
Q3127	BC857B	TRANSISTOR OR 2SB709ATX
Q3131	2SB940APLB	TRANSISTOR
Q3136	2SD1264APLB	TRANSISTOR
Q3143	BC847B	TRANSISTOR OR 2SD601ATX
Q3162	BC857B	TRANSISTOR OR 2SB709ATX
Q3164	BC847B	TRANSISTOR OR 2SD601ATX
Q3166	BC857B	TRANSISTOR OR 2SB709ATX
Q3169	BC857B	TRANSISTOR OR 2SB709ATX
Q3172	BC857B	TRANSISTOR OR 2SB709ATX
Q3174	BC847B	TRANSISTOR OR 2SD601ATX
Q3176	BC857B	TRANSISTOR OR 2SB709ATX
Q3179	BC857B	TRANSISTOR OR 2SB709ATX
Q3182	BC857B	TRANSISTOR OR 2SB709ATX
Q3184	BC847B	TRANSISTOR OR 2SD601ATX
Q3186	BC857B	TRANSISTOR OR 2SB709ATX
Q3189	BC857B	TRANSISTOR OR 2SB709ATX
Q3359	BC847B	TRANSISTOR OR 2SD601ATX
Q3368	2SB710A-XR	TRANSISTOR
Q3371	BC857B	TRANSISTOR OR 2SB709ATX
Q3373	2SC4714RL2	TRANSISTOR
Q3374	2SC3063RL	TRANSISTOR
Q3377	2SA1698RL	TRANSISTOR
Q3381	BC857B	TRANSISTOR OR 2SB709ATX
Q3383	2SC4714RL2	TRANSISTOR
Q3384	2SC3063RL	TRANSISTOR
Q3387	2SA1698RL	TRANSISTOR
Q3391	BC857B	TRANSISTOR OR 2SB709ATX
Q3392	2SA1309ATA	TRANSISTOR
Q3393	2SC4714RL2	TRANSISTOR
Q3394	2SC3063RL	TRANSISTOR
Q3397	2SA1698RL	TRANSISTOR
Q4701	BC847B	TRANSISTOR OR 2SD601ATX
Q4702	BC847B	TRANSISTOR OR 2SD601ATX
Q4703	BC847B	TRANSISTOR OR 2SD601ATX
Q4704	BF370-126	TRANSISTOR
Q4705	BF370-126	TRANSISTOR
Q6111	BC847B	TRANSISTOR OR 2SD601ATX
Q6114	BC847B	TRANSISTOR OR 2SD601ATX
Q6403	BC847B	TRANSISTOR OR 2SD601ATX
Q6413	BC847B	TRANSISTOR OR 2SD601ATX

Ref No.	Part No.	Description
Q6417	BC857B	TRANSISTOR OR 2SB709ATX
Q6433	BC847B	TRANSISTOR OR 2SD601ATX
Q6443	BC847B	TRANSISTOR OR 2SD601ATX
Q6447	BC857B	TRANSISTOR OR 2SB709ATX
RESISTOR		
RL6101	TSE10818	RELAY
R201	ERD25TJ223	CARBON 0.25W 5% 22KΩ
R206	ERG2ANJ223	METAL 2W 5% 22KΩ
R259	ERD25TJ473	CARBON 0.25W 5% 47KΩ
R462	ERD25TJ101	CARBON 0.25W 5% 100Ω
R463	ERD25TJ103	CARBON 0.25W 5% 10KΩ
R466	ERD25TJ153	CARBON 0.25W 5% 15KΩ
R470	ERD25TJ270	CARBON 0.25W 5% 27Ω
R471	ERD25TJ102	CARBON 0.25W 5% 1KΩ
R472	ERD25TJ333	CARBON 0.25W 5% 33KΩ
R473	ERD25TJ270	CARBON 0.25W 5% 27Ω
R477	ERD25TJ105	CARBON 0.25W 5% 1MΩ
R478	ERD25TJ332	CARBON 0.25W 5% 3K3Ω
R479	ERDS1TJ2R2	CARBON 0.5W 5% 2.2Ω
R480	ERD25TJ270	CARBON 0.25W 5% 27Ω
R481	ERD25TJ102	CARBON 0.25W 5% 1KΩ
R482	ERD25TJ333	CARBON 0.25W 5% 33KΩ
R483	ERD25TJ270	CARBON 0.25W 5% 27Ω
R484	ERD25TJ273	CARBON 0.25W 5% 27KΩ
R485	ERD25TJ561	CARBON 0.25W 5% 560Ω
R486	ERD25TJ333	CARBON 0.25W 5% 33KΩ
R487	ERD25TJ105	CARBON 0.25W 5% 1MΩ
R488	ERD25TJ332	CARBON 0.25W 5% 3K3Ω
R489	ERDS1TJ2R2	CARBON 0.5W 5% 2.2Ω
R490	ERD25TJ563	CARBON 0.25W 5% 56KΩ
R491	ERQ14AJ100	METAL 0.25W 5% 10Ω ▲
R492	ERD25TJ473	CARBON 0.25W 5% 47KΩ
R493	ERD25TJ473	CARBON 0.25W 5% 47KΩ
R494	ERD25TJ684	CARBON 0.25W 5% 680KΩ
R496	ERD25TJ103	CARBON 0.25W 5% 10KΩ
R497	ERD25TJ103	CARBON 0.25W 5% 10KΩ
R498	ERD25TJ103	CARBON 0.25W 5% 10KΩ
R499	ERD25TJ473	CARBON 0.25W 5% 47KΩ
R501	ERD25TJ470	CARBON 0.25W 5% 47Ω
R507	ERD25TJ2R2	CARBON 0.25W 5% 2R2Ω
R521	ERQ14AJ3R3	METAL 0.25W 5% 3R3Ω ▲
R526	ERD25TJ560	CARBON 0.25W 5% 56Ω
R527	ERDS1TJ152	CARBON 0.5W 5% 1K5Ω
R528	ERDS1TJ152	CARBON 0.5W 5% 1K5Ω
R531	ERF10ZK6R8	WIRE 10W 5% 6R8Ω ▲
R532	ERW2PKR47	WIREWOUND2W 10% R47Ω ▲
R533	ERDS1TJ220	CARBON 0.5W 5% 22Ω
R541	ERG1ANJ152	METAL 1W 5% 1K5Ω
R542	ERQ1ABJ101	FUSIBLE 1W 5% 100Ω ▲
R543	ERD25TJ103	CARBON 0.25W 5% 10KΩ
R546	ERDS1TJ184	CARBON 0.5W 5% 180K
R548	ERD25TJ223	CARBON 0.25W 5% 22KΩ
R549	ERDS1TJ224	CARBON 0.5W 5% 220KΩ
R557	ERQ12HJR22	FUSIBLE 0.5W 5% R22Ω ▲
R559	ERDS1TJ100	CARBON 0.5W 5% 10Ω
R561	ERQ12HJ1R5	FUSIBLE 0.5W 5% 1R5Ω ▲
R563	ERD25TJ104	CARBON 0.25W 5% 100KΩ
R564	ERD25TJ223	CARBON 0.25W 5% 22KΩ
R566	ERD25TJ472	CARBON 0.25W 5% 4K7Ω
R567	ERD25TJ472	CARBON 0.25W 5% 4K7Ω
R568	ERD25TJ1R5	CARBON 0.25W 5% 1R5Ω
R569	ERDS1TJ221	CARBON 0.5W 5% 220Ω
R572	ERO25CKF1801	METAL 0.25W 1% 1K8Ω ▲
R573	ERO25CKF1801	METAL 0.25W 1% 1K8Ω ▲
R574	ERW12PKR56	WIREWOUND0.5W 10% R56Ω ▲
R576	ERD25TJ682	CARBON 0.25W 5% 6K8Ω
R577	ERD25TJ822	CARBON 0.25W 5% 8K2Ω
R578	ERD25TJ680	CARBON 0.25W 5% 68Ω

Ref No.	Part No.	Description
R579	ERD25TJ332	CARBON 0.25W 5% 3K3Ω
R583	ERD25TJ103	CARBON 0.25W 5% 10KΩ
R584	ERO25CKF1002	METAL 0.25W 1% 10KΩ ▲
R590	ERD25TJ224	CARBON 0.25W 5% 220KΩ
R591	ERD25TJ472	CARBON 0.25W 5% 4K7Ω
R592	ERD25TJ103	CARBON 0.25W 5% 10KΩ
R593	ERD25TJ103	CARBON 0.25W 5% 10KΩ
R594	ERD25TJ394	CARBON 0.25W 5% 390KΩ
R595	ERD25TJ473	CARBON 0.25W 5% 47KΩ
R596	ERD25TJ473	CARBON 0.25W 5% 47KΩ
R597	ERD25TJ475	CARBON 0.25W 5% 4M7Ω
R598	ERD25TJ102	CARBON 0.25W 5% 1KΩ
R599	ERD25TJ103	CARBON 0.25W 5% 10KΩ
R613	ERF10ZK5R6	WIRE 10W 5% 5R6Ω ▲
R614	ERDS1TJ394	CARBON 0.5W 5% 390KΩ
R616	ERC12GK154D	SOLID 0.5W 10% 150KΩ
R619	232266296706	THERMISTOR
R621	ERG2FJ183	METAL 0.5W 5% 18KΩ ▲
R622	ERDS1TJ394	CARBON 0.5W 5% 390KΩ
R623	ERD25TJ472	CARBON 0.25W 5% 4K7Ω
R624	ERD25TJ121	CARBON 0.25W 5% 120Ω
R625	ERC12GK154D	SOLID 0.5W 10% 150KΩ
R626	ERG2FJ183	METAL 0.5W 5% 18KΩ ▲
R627	ERD25TJ103	CARBON 0.25W 5% 10KΩ
R628	ERG3FJ393	METAL 0.25W 5% 39KΩ ▲
R629	ERG1ANJ470	METAL 1W 5% 47Ω
R630	ERD25TJ270	CARBON 0.25W 5% 27Ω
R631	ERD25TJ101	CARBON 0.25W 5% 100Ω
R632	ERO25CKF1400	METAL 0.25W 1% 140Ω ▲
R633	ERO25CKF3921	METAL 0.25W 1% 3R92KΩ ▲
R634	ERDS1TJ1R5	CARBON 0.5W 5% 1R5Ω
R636	ERD25TJ473	CARBON 0.25W 5% 47KΩ
R639	ERD75TAJ825	CARBON 0.75W 5% 8M2Ω ▲
R651	ERDS1TJ474	CARBON 0.5W 5% 470KΩ
R652	ERD25TJ102	CARBON 0.25W 5% 1KΩ
R666	ERO25CKF3301	METAL 0.25W 1% 3K3Ω ▲
R667	ERO25CKF3900	METAL 0.25W 1% 3R9KΩ ▲
R674	ERD25TJ223	CARBON 0.25W 5% 22KΩ
R675	ERD25TJ155	CARBON 0.25W 5% 1M5Ω
R676	ERO25CKF1002	METAL 0.25W 1% 10KΩ ▲
R677	ERO25CKF1002	METAL 0.25W 1% 10KΩ ▲
R678	ERD25TJ121	CARBON 0.25W 5% 120Ω
R680	ERQ12HJ1R5	FUSIBLE 0.5W 5% 1R5Ω ▲
R681	ERDS1TJ4R7	CARBON 0.5W 5% 4R7Ω
R682	ERD25TJ222	CARBON 0.25W 5% 2K2Ω
R683	ERG3FJ101	METAL 3W 5% 100Ω ▲
R684	ERD25TJ682	CARBON 0.25W 5% 6K8Ω
R686	FN4R1KR	FUSIBLE 0.25W 5% 0.1Ω
R688	FN4R1KR	FUSIBLE 0.25W 5% 0.1Ω
R1001	ERQ14AJ3R3	METAL 0.25W 5% 3R3Ω ▲
R1011	ERQ14AJ100	METAL 0.25W 5% 10Ω ▲
R1019	ERJ6GEYJ101	S.M.CARB 0.1W 5% 100Ω
R1020	ERJ6GEYJ101	S.M.CARB 0.1W 5% 100Ω
R1021	ERJ6GEYJ153	S.M.CARB 0.1W 5% 15KΩ
R1022	ERJ6GEYJ153	S.M.CARB 0.1W 5% 15KΩ
R1023	ERJ6GEYJ101	S.M.CARB 0.1W 5% 100Ω
R1024	ERJ6GEYJ101	S.M.CARB 0.1W 5% 100Ω
R1031	ERJ6GEYJ153	S.M.CARB 0.1W 5% 15KΩ
R1032	ERJ6GEYJ153	S.M.CARB 0.1W 5% 15KΩ
R1033	ERJ6GEYJ101	S.M.CARB 0.1W 5% 100Ω
R1034	ERJ6GEYJ101	S.M.CARB 0.1W 5% 100Ω
R1036	ERJ6GEYJ101	S.M.CARB 0.1W 5% 100Ω
R1038	ERJ6GEYJ101	S.M.CARB 0.1W 5% 100Ω
R1041	ERJ6GEYJ101	S.M.CARB 0.1W 5% 100Ω
R1042	ERJ6GEYJ101	S.M.CARB 0.1W 5% 100Ω
R1116	ERJ6GEYJ104	S.M.CARB 0.1W 5% 100KΩ
R1117	ERJ6GEYJ104	S.M.CARB 0.1W 5% 100KΩ
R1120	ERJ6GEYJ101	S.M.CARB 0.1W 5% 100Ω
R1121	ERJ6GEYJ750	S.M.CARB 0.1W 5% 75Ω
R1122	ERJ6GEYJ750	S.M.CARB 0.1W 5% 75Ω
R1123	ERJ6GEYJ102	S.M.CARB 0.1W 5% 1KΩ

Ref No.	Part No.	Description
R1124	ERJ6GEYJ151	S.M.CARB 0.1W 5% 150Ω
R1125	ERJ6GEYJ151	S.M.CARB 0.1W 5% 150Ω
R1126	ERQ14AJ100	METAL 0.25W 5% 10Ω ▲
R1127	ERJ6GEYOR00	S.M.CARB 0.1W 5% 0Ω
R1131	ERJ6GEYJ101	S.M.CARB 0.1W 5% 100Ω
R1132	ERJ6GEYJ103	S.M.CARB 0.1W 5% 10KΩ
R1133	ERJ6GEYJ103	S.M.CARB 0.1W 5% 10KΩ
R1151	ERJ6GEYJ750	S.M.CARB 0.1W 5% 75Ω
R1152	ERJ6GEYJ104	S.M.CARB 0.1W 5% 100KΩ
R1153	ERJ6GEYJ104	S.M.CARB 0.1W 5% 100KΩ
R1156	ERJ6GEYJ470	S.M.CARB 0.1W 5% 47Ω
R1158	ERJ6GEYJ101	S.M.CARB 0.1W 5% 100Ω
R1159	ERJ6GEYJ750	S.M.CARB 0.1W 5% 75Ω
R1161	ERJ6GEYJ682	S.M.CARB 0.1W 5% 6K8Ω
R1162	ERJ6GEYJ333	S.M.CARB 0.1W 5% 33KΩ
R1163	ERJ6GEYJ471	S.M.CARB 0.1W 5% 470Ω
R1166	ERJ6GEYJ103	S.M.CARB 0.1W 5% 10KΩ
R1167	ERJ6GEYJ101	S.M.CARB 0.1W 5% 100Ω
R1168	ERJ6GEYJ680	S.M.CARB 0.1W 5% 68Ω
R1169	ERJ6GEYJ471	S.M.CARB 0.1W 5% 470Ω
R1171	ERJ6GEYJ750	S.M.CARB 0.1W 5% 75Ω
R1172	ERJ6GEYJ102	S.M.CARB 0.1W 5% 1KΩ
R1173	ERJ6GEYJ151	S.M.CARB 0.1W 5% 150Ω
R1174	ERJ6GEYJ151	S.M.CARB 0.1W 5% 150Ω
R1177	ERJ6GEYJ561	S.M.CARB 0.1W 5% 560Ω
R1178	ERQ14AJ100	METAL 0.25W 5% 10Ω ▲
R1181	ERJ6GEYJ103	S.M.CARB 0.1W 5% 10KΩ
R1182	ERJ6GEYJ101	S.M.CARB 0.1W 5% 100Ω
R1183	ERJ6GEYJ680	S.M.CARB 0.1W 5% 68Ω
R1184	ERJ6GEYJ103	S.M.CARB 0.1W 5% 10KΩ
R1185	ERJ6GEYJ151	S.M.CARB 0.1W 5% 150Ω
R1191	ERJ6GEYJ103	S.M.CARB 0.1W 5% 10KΩ
R1192	ERJ6GEYJ101	S.M.CARB 0.1W 5% 100Ω
R1193	ERJ6GEYJ680	S.M.CARB 0.1W 5% 68Ω
R1194	ERJ6GEYJ103	S.M.CARB 0.1W 5% 10KΩ
R1195	ERJ6GEYJ750	S.M.CARB 0.1W 5% 75Ω
R1221	ERJ6GEYJ473	S.M.CARB 0.1W 5% 47KΩ
R1222	ERJ6GEYJ473	S.M.CARB 0.1W 5% 47KΩ
R1225	ERJ6GEYJ101	S.M.CARB 0.1W 5% 100Ω
R1237	ERJ6GEYJ103	S.M.CARB 0.1W 5% 10KΩ
R1241	ERJ6GEYJ102	S.M.CARB 0.1W 5% 1KΩ
R1242	ERJ6GEYJ102	S.M.CARB 0.1W 5% 1KΩ
R1251	ERJ6GEYJ750	S.M.CARB 0.1W 5% 75Ω
R1270	ERJ6GEYJ470	S.M.CARB 0.1W 5% 47Ω
R1271	ERJ6GEYJ750	S.M.CARB 0.1W 5% 75Ω
R1272	ERJ6GEYJ750	S.M.CARB 0.1W 5% 75Ω
R1273	ERJ6GEYJ470	S.M.CARB 0.1W 5% 47Ω
R1276	ERJ6GEYJ104	S.M.CARB 0.1W 5% 100KΩ
R1277	ERJ6GEYJ104	S.M.CARB 0.1W 5% 100KΩ
R1281	ERJ6GEYJ153	S.M.CARB 0.1W 5% 15KΩ
R1282	ERJ6GEYJ101	S.M.CARB 0.1W 5% 100Ω
R1283	ERJ6GEYJ153	S.M.CARB 0.1W 5% 15KΩ
R1284	ERJ6GEYJ101	S.M.CARB 0.1W 5% 100Ω
R1349	ERJ6GEYJ473	S.M.CARB 0.1W 5% 47KΩ
R1381	ERJ6GEYJ223	S.M.CARB 0.1W 5% 22KΩ
R1382	ERJ6GEYJ473	S.M.CARB 0.1W 5% 47KΩ
R1386	ERJ6GEYOR00	S.M.CARB 0.1W 5% 0Ω
R1412	ERJ6GEYJ471	S.M.CARB 0.1W 5% 470Ω
R1464	ERJ6GEYJ101	S.M.CARB 0.1W 5% 100Ω
R1465	ERJ6GEYJ183	S.M.CARB 0.1W 5% 18KΩ
R1466	ERJ6GEYJ222	S.M.CARB 0.1W 5% 2K2Ω
R1467	ERJ6GEYOR00	S.M.CARB 0.1W 5% 0Ω
R1474	ERJ6GEYJ101	S.M.CARB 0.1W 5% 100Ω
R1476	ERJ6GEYJ222	S.M.CARB 0.1W 5% 2K2Ω
R1477	ERJ6GEYOR00	S.M.CARB 0.1W 5% 0Ω
R1484	ERJ6GEYJ101	S.M.CARB 0.1W 5% 100Ω
R1486	ERJ6GEYJ222	S.M.CARB 0.1W 5% 2K2Ω
R1487	ERJ6GEYJ471	S.M.CARB 0.1W 5% 470Ω
R1494	ERJ6GEYJ101	S.M.CARB 0.1W 5% 100Ω
R1496	ERJ6GEYJ222	S.M.CARB 0.1W 5% 2K2Ω
R1497	ERJ6GEYJ471	S.M.CARB 0.1W 5% 470Ω
R1608	ERJ6GEYOR00	S.M.CARB 0.1W 5% 0Ω

Ref No.	Part No.	Description
R1612	ERJ6GEYJ101	S.M.CARB 0.1W 5% 100Ω
R1613	ERJ6GEYJ560	S.M.CARB 0.1W 5% 56Ω
R1614	ERJ6GEYJ331	S.M.CARB 0.1W 5% 330Ω
R1615	ERJ6GEYJ221	S.M.CARB 0.1W 5% 220Ω
R1616	ERJ6GEYJ151	S.M.CARB 0.1W 5% 150Ω
R1617	ERJ6GEYJ333	S.M.CARB 0.1W 5% 33KΩ
R1618	ERJ6GEYJ151	S.M.CARB 0.1W 5% 150Ω
R1619	ERJ6GEYJ151	S.M.CARB 0.1W 5% 150Ω
R1621	ERJ6GEYJ102	S.M.CARB 0.1W 5% 1KΩ
R1622	ERJ6GEYJ103	S.M.CARB 0.1W 5% 10KΩ
R1623	ERJ6GEYJ123	S.M.CARB 0.1W 5% 12KΩ
R1624	ERJ6GEYJ333	S.M.CARB 0.1W 5% 33KΩ
R1626	ECUV1H151JCX	S.M.CAP 50V 150pF
R1627	ERJ6GEYJ750	S.M.CARB 0.1W 5% 75Ω
R1630	ERJ6GEYJ101	S.M.CARB 0.1W 5% 100Ω
R1631	ERJ6GEYJ470	S.M.CARB 0.1W 5% 47Ω
R1632	ERJ6GEYJ471	S.M.CARB 0.1W 5% 470Ω
R1633	ERJ6GEYJ101	S.M.CARB 0.1W 5% 100Ω
R1634	ERJ6GEYJ332	S.M.CARB 0.1W 5% 3K3Ω
R1636	ERJ6GEYJ750	S.M.CARB 0.1W 5% 75Ω
R1637	ERJ8GEYJ471	S.M.CAR .125W 5% 470Ω
R1641	ERJ6GEYJ821	S.M.CARB 0.1W 5% 820Ω
R1642	ERJ6GEYJ471	S.M.CARB 0.1W 5% 470Ω
R1643	ERJ6GEYJ101	S.M.CARB 0.1W 5% 100Ω
R1644	ERJ6GEYJ332	S.M.CARB 0.1W 5% 3K3Ω
R1646	ERJ6GEYJ750	S.M.CARB 0.1W 5% 75Ω
R1647	ERJ8GEYJ471	S.M.CAR .125W 5% 470Ω
R1652	ERJ6GEYJ471	S.M.CARB 0.1W 5% 470Ω
R1653	ERJ6GEYJ101	S.M.CARB 0.1W 5% 100Ω
R1654	ERJ6GEYJ332	S.M.CARB 0.1W 5% 3K3Ω
R1656	ERJ6GEYJ750	S.M.CARB 0.1W 5% 75Ω
R1657	ERJ8GEYJ471	S.M.CAR .125W 5% 470Ω
R1661	ERJ6GEYJ472	S.M.CARB 0.1W 5% 4K7Ω
R1664	ERJ6GEYJ472	S.M.CARB 0.1W 5% 4K7Ω
R1666	ERJ6GEYJ472	S.M.CARB 0.1W 5% 4K7Ω
R1667	ERJ6GEYJ104	S.M.CARB 0.1W 5% 100KΩ
R1668	ERJ6GEYJ474	S.M.CARB 0.1W 5% 470KΩ
R1669	ERJ6GEYJ472	S.M.CARB 0.1W 5% 4K7Ω
R1670	ERJ6GEYJ472	S.M.CARB 0.1W 5% 4K7Ω
R1671	ERJ6GEYJ472	S.M.CARB 0.1W 5% 4K7Ω
R1672	ERJ6GEYJ472	S.M.CARB 0.1W 5% 4K7Ω
R1673	ERJ6GEYJ101	S.M.CARB 0.1W 5% 100Ω
R1674	ERJ6GEYJ472	S.M.CARB 0.1W 5% 4K7Ω
R1681	ERJ6GEYJ472	S.M.CARB 0.1W 5% 4K7Ω
R1682	ERJ6GEYJ473	S.M.CARB 0.1W 5% 47KΩ
R1683	ERJ6GEYJ102	S.M.CARB 0.1W 5% 1KΩ
R1691	ERJ6GEYJ750	S.M.CARB 0.1W 5% 75Ω
R1692	ERJ6GEYJ750	S.M.CARB 0.1W 5% 75Ω
R1693	ERJ6GEYJ750	S.M.CARB 0.1W 5% 75Ω
R1694	ERJ6GEYJ750	S.M.CARB 0.1W 5% 75Ω
R1696	ERJ8GEYJ103	S.M.CAR .125W 5% 10KΩ
R1698	ERJ6GEYJ472	S.M.CARB 0.1W 5% 4K7Ω
R1717	ERJ6GEYJ102	S.M.CARB 0.1W 5% 1KΩ
R1718	ERJ6GEYJ103	S.M.CARB 0.1W 5% 10KΩ
R1719	ERJ6GEYJ472	S.M.CARB 0.1W 5% 4K7Ω
R1753	ERJ6GEY0R00	S.M.CARB 0.1W 5% 0Ω
R1807	ERJ6GEYJ222	S.M.CARB 0.1W 5% 2K2Ω
R1808	ERJ6GEYJ472	S.M.CARB 0.1W 5% 4K7Ω
R1809	ERJ6GEYJ472	S.M.CARB 0.1W 5% 4K7Ω
R1811	ERJ6GEYJ101	S.M.CARB 0.1W 5% 100Ω
R1812	ERJ6GEYJ472	S.M.CARB 0.1W 5% 4K7Ω
R1815	ERJ6GEYJ101	S.M.CARB 0.1W 5% 100Ω
R1816	ERJ6GEYJ473	S.M.CARB 0.1W 5% 47KΩ
R1819	ERJ6GEYJ472	S.M.CARB 0.1W 5% 4K7Ω
R1821	ERJ6GEYJ102	S.M.CARB 0.1W 5% 1KΩ
R1822	ERJ6GEYJ392	S.M.CARB 0.1W 5% 3K9Ω
R1823	ERJ6GEYJ472	S.M.CARB 0.1W 5% 4K7Ω
R1824	ERJ6GEYJ473	S.M.CARB 0.1W 5% 47KΩ
R1825	ERJ6GEYJ101	S.M.CARB 0.1W 5% 100Ω
R1826	ERJ6GEYJ563	S.M.CARB 0.1W 5% 56KΩ
R1827	ERJ6GEYJ393	S.M.CARB 0.1W 5% 39KΩ
R1828	ERJ6GEYJ472	S.M.CARB 0.1W 5% 4K7Ω

Ref No.	Part No.	Description
R1829	ERJ6GEYJ102	S.M.CARB 0.1W 5% 1KΩ
R1831	ERJ6GEYJ392	S.M.CARB 0.1W 5% 3K9Ω
R1832	ERJ6GEYJ472	S.M.CARB 0.1W 5% 4K7Ω
R1837	ERJ6GEYJ562	S.M.CARB 0.1W 5% 5K6Ω
R1838	ERJ6GEYJ331	S.M.CARB 0.1W 5% 330Ω
R1840	ERJ6GEY0R00	S.M.CARB 0.1W 5% 0Ω
R1842	ERJ6GEYJ103	S.M.CARB 0.1W 5% 10KΩ
R1843	ERJ6GEYJ472	S.M.CARB 0.1W 5% 4K7Ω
R1844	ERJ6GEYJ103	S.M.CARB 0.1W 5% 10KΩ
R1845	ERJ6GEYJ470	S.M.CARB 0.1W 5% 47Ω
R1847	ERJ6GEYJ103	S.M.CARB 0.1W 5% 10KΩ
R1849	ERJ6GEYJ103	S.M.CARB 0.1W 5% 10KΩ
R1850	ERJ6GEY0R00	S.M.CARB 0.1W 5% 0Ω
R1851	ERJ6GEYJ472	S.M.CARB 0.1W 5% 4K7Ω
R1856	ERJ6GEYJ472	S.M.CARB 0.1W 5% 4K7Ω
R1857	ERJ6GEYJ101	S.M.CARB 0.1W 5% 100Ω
R1858	ERJ8GEYJ562	S.M.CAR .125W 5% 5K6Ω
R1859	ERJ6GEYJ101	S.M.CARB 0.1W 5% 100Ω
R1863	ERJ6GEYJ472	S.M.CARB 0.1W 5% 4K7Ω
R1872	ERJ6GEYJ472	S.M.CARB 0.1W 5% 4K7Ω
R1873	ERJ6GEYJ103	S.M.CARB 0.1W 5% 10KΩ
R1878	ERJ6GEYJ101	S.M.CARB 0.1W 5% 100Ω
R1879	ERJ6GEYJ103	S.M.CARB 0.1W 5% 10KΩ
R1882	ERJ6GEYJ103	S.M.CARB 0.1W 5% 10KΩ
R1884	ERJ6GEYJ222	S.M.CARB 0.1W 5% 2K2Ω
R1885	ERJ8GEY0R00	S.M.CAR .125W 5% 0Ω
R1886	ERJ6GEYJ222	S.M.CARB 0.1W 5% 2K2Ω
R1887	ERJ6GEY0R00	S.M.CARB 0.1W 5% 0Ω
R1888	ERJ6GEYJ472	S.M.CARB 0.1W 5% 4K7Ω
R1889	ERJ8GEY0R00	S.M.CAR .125W 5% 0Ω
R1893	ERJ6GEYJ472	S.M.CARB 0.1W 5% 4K7Ω
R1897	ERJ6GEYJ103	S.M.CARB 0.1W 5% 10KΩ
R1920	ERJ8GEYJ223	S.M.CAR .125 5% 22KΩ
R1921	ERJ6GEYJ472	S.M.CARB 0.1W 5% 4K7Ω
R1922	ERJ6GEYJ471	S.M.CARB 0.1W 5% 470Ω
R1925	ERJ6GEYJ331	S.M.CARB 0.1W 5% 330Ω
R1933	ERJ6GEY0R00	S.M.CARB 0.1W 5% 0Ω
R1941	ERJ6GEY0R00	S.M.CARB 0.1W 5% 0Ω
R1953	ERJ6GEYJ101	S.M.CARB 0.1W 5% 100Ω
R1957	ERJ6GEYJ101	S.M.CARB 0.1W 5% 100Ω
R1958	ERJ6GEYJ101	S.M.CARB 0.1W 5% 100Ω
R1959	ERJ6GEYJ101	S.M.CARB 0.1W 5% 100Ω
R1961	ERJ6GEYJ101	S.M.CARB 0.1W 5% 100Ω
R1962	ERJ6GEYJ101	S.M.CARB 0.1W 5% 100Ω
R1963	ERJ6GEYJ101	S.M.CARB 0.1W 5% 100Ω
R1964	ERJ6GEYJ101	S.M.CARB 0.1W 5% 100Ω
R1983	ERJ6GEYJ103	S.M.CARB 0.1W 5% 10KΩ
R1993	ERJ6GEYJ101	S.M.CARB 0.1W 5% 100Ω
R2401	ERJ6GEYJ563	S.M.CARB 0.1W 5% 56KΩ
R2402	ERJ6GEYJ563	S.M.CARB 0.1W 5% 56KΩ
R2403	ERJ6GEYJ104	S.M.CARB 0.1W 5% 100KΩ
R2404	ERJ6GEYJ104	S.M.CARB 0.1W 5% 100KΩ
R2405	ERJ6GEYJ223	S.M.CARB 0.1W 5% 22KΩ
R2406	ERJ6GEYJ332	S.M.CARB 0.1W 5% 3K3Ω
R2408	ERJ6GEYJ222	S.M.CARB 0.1W 5% 2K2Ω
R2409	ERJ6GEYJ1R0	SM.CARB0.125W 5% 1R0Ω
R2410	ERJ6GEYJ183	S.M.CARB 0.1W 5% 18KΩ
R2411	ERJ6GEYJ391	S.M.CARB 0.1W 5% 390Ω
R2412	ERJ6GEYJ223	S.M.CARB 0.1W 5% 22KΩ
R2413	ERJ6GEYJ101	S.M.CARB 0.1W 5% 100Ω
R2416	ERJ6GEY0R00	S.M.CARB 0.1W 5% 0Ω
R2417	ERJ6GEY0R00	S.M.CARB 0.1W 5% 0Ω
R2418	ERJ6GEY0R00	S.M.CARB 0.1W 5% 0Ω
R2419	ERJ6GEY0R00	S.M.CARB 0.1W 5% 0Ω
R2420	ERJ6GEY0R00	S.M.CARB 0.1W 5% 0Ω
R2421	ERJ6GEY0R00	S.M.CARB 0.1W 5% 0Ω
R2422	ERJ6GEY0R00	S.M.CARB 0.1W 5% 0Ω
R2423	ERJ6GEYJ104	S.M.CARB 0.1W 5% 100KΩ
R2424	ERJ6GEYJ332	S.M.CARB 0.1W 5% 3K3Ω
R2425	ERJ6GEYJ273	S.M.CARB 0.1W 5% 27KΩ
R2426	ERJ6GEYJ104	S.M.CARB 0.1W 5% 100KΩ
R2427	ERJ6GEYJ102	S.M.CARB 0.1W 5% 1KΩ

Ref No.	Part No.	Description
R2428	ERJ6GEYJ821	S.M.CARB 0.1W 5% 820Ω
R2430	ERJ6GEYJ153	S.M.CARB 0.1W 5% 15KΩ
R2431	ERJ6GEYJ223	S.M.CARB 0.1W 5% 22KΩ
R2434	ERJ6GEYJ103	S.M.CARB 0.1W 5% 10KΩ
R2435	ERJ6GEYJ103	S.M.CARB 0.1W 5% 10KΩ
R2436	ERJ6GEYJ104	S.M.CARB 0.1W 5% 100KΩ
R2437	ERJ6GEYJ821	S.M.CARB 0.1W 5% 820Ω
R2438	ERJ6GEYJ104	S.M.CARB 0.1W 5% 100KΩ
R2439	ERJ6GEYJ821	S.M.CARB 0.1W 5% 820Ω
R2440	ERJ6GEYJ273	S.M.CARB 0.1W 5% 27KΩ
R2441	ERJ6GEYJ104	S.M.CARB 0.1W 5% 100KΩ
R2442	ERJ6GEYJ102	S.M.CARB 0.1W 5% 1KΩ
R2443	ERJ6GEYJ473	S.M.CARB 0.1W 5% 47KΩ
R2444	ERJ6GEYJ101	S.M.CARB 0.1W 5% 100Ω
R2446	ERJ6GEYJ101	S.M.CARB 0.1W 5% 100Ω
R2447	ERJ6GEYJ472	S.M.CARB 0.1W 5% 4K7Ω
R2448	ERJ6GEYJ104	S.M.CARB 0.1W 5% 100KΩ
R2449	ERJ6GEYJ103	S.M.CARB 0.1W 5% 10KΩ
R2450	ERJ6GEYJ104	S.M.CARB 0.1W 5% 100KΩ
R2451	ERJ6GEYJ104	S.M.CARB 0.1W 5% 100KΩ
R2452	ERJ6GEYJ472	S.M.CARB 0.1W 5% 4K7Ω
R2453	ERJ6GEYJ224	S.M.CARB 0.1W 5% 22KΩ
R2454	ERJ6GEYJ224	S.M.CARB 0.1W 5% 22KΩ
R2455	ERJ6GEYJ104	S.M.CARB 0.1W 5% 100KΩ
R2456	ERJ6GEYJ821	S.M.CARB 0.1W 5% 820Ω
R2457	ERJ6GEYJ273	S.M.CARB 0.1W 5% 27KΩ
R2458	ERJ6GEYJ104	S.M.CARB 0.1W 5% 100KΩ
R2459	ERJ6GEYJ102	S.M.CARB 0.1W 5% 1KΩ
R2461	ERJ6GEYJ101	S.M.CARB 0.1W 5% 100Ω
R2462	ERJ6GEYJ104	S.M.CARB 0.1W 5% 100KΩ
R2463	ERJ6GEYJ104	S.M.CARB 0.1W 5% 100KΩ
R2464	ERJ6GEYJ472	S.M.CARB 0.1W 5% 4K7Ω
R2465	ERJ6GEYJ104	S.M.CARB 0.1W 5% 100KΩ
R2466	ERJ6GEYJ821	S.M.CARB 0.1W 5% 820Ω
R2467	ERJ6GEYJ273	S.M.CARB 0.1W 5% 27KΩ
R2468	ERJ6GEYJ104	S.M.CARB 0.1W 5% 100KΩ
R2469	ERJ6GEYJ102	S.M.CARB 0.1W 5% 1KΩ
R2470	ERJ6GEYJ473	S.M.CARB 0.1W 5% 47KΩ
R2471	ERJ6GEYJ822	S.M.CARB 0.1W 5% 8K2Ω
R2473	ERJ6GEYJ101	S.M.CARB 0.1W 5% 100Ω
R2474	ERJ6GEYJ104	S.M.CARB 0.1W 5% 100KΩ
R2475	ERJ6GEYJ104	S.M.CARB 0.1W 5% 100KΩ
R2476	ERJ6GEYJ183	S.M.CARB 0.1W 5% 18KΩ
R2477	ERJ6GEYJ104	S.M.CARB 0.1W 5% 100KΩ
R2478	ERJ6GEYJ332	S.M.CARB 0.1W 5% 3K3Ω
R2479	ERJ6GEYJ104	S.M.CARB 0.1W 5% 100KΩ
R2480	ERJ6GEYJ104	S.M.CARB 0.1W 5% 100KΩ
R2481	ERJ6GEYJ472	S.M.CARB 0.1W 5% 4K7Ω
R2482	ERJ6GEYJ104	S.M.CARB 0.1W 5% 100KΩ
R2483	ERJ6GEYJ332	S.M.CARB 0.1W 5% 3K3Ω
R2484	ERJ6GEYJ273	S.M.CARB 0.1W 5% 27KΩ
R2485	ERJ6GEYJ104	S.M.CARB 0.1W 5% 100KΩ
R2486	ERJ6GEYJ102	S.M.CARB 0.1W 5% 1KΩ
R2487	ERJ6GEYJ103	S.M.CARB 0.1W 5% 10KΩ
R2488	ERJ6GEYJ105	S.M.CARB 0.1W 5% 1MΩ
R2489	ERJ6GEYJ103	S.M.CARB 0.1W 5% 10KΩ
R2490	ERJ6GEYJ472	S.M.CARB 0.1W 5% 4K7Ω
R2491	ERJ6GEYJ153	S.M.CARB 0.1W 5% 15KΩ
R2492	ERJ6GEYJ472	S.M.CARB 0.1W 5% 4K7Ω
R2493	ERJ6GEYJ472	S.M.CARB 0.1W 5% 4K7Ω
R2494	ERJ6GEYJ273	S.M.CARB 0.1W 5% 27KΩ
R2495	ERJ6GEYJ102	S.M.CARB 0.1W 5% 1KΩ
R2496	ERJ6GEYJ102	S.M.CARB 0.1W 5% 1KΩ
R2497	ERJ6GEYJ472	S.M.CARB 0.1W 5% 4K7Ω
R2498	ERJ6GEYJ101	S.M.CARB 0.1W 5% 100Ω
R2499	ERJ6GEYJ101	S.M.CARB 0.1W 5% 100Ω
R2502	ERDS1TJ154	CARBON 0.5W 5% 150K
R2503	ERDS1TJ184	CARBON 0.5W 5% 180K
R2504	ERG5FJ473	METAL 5W 5% 47KΩ ▲
R2505	ERG1FJ101P	METAL 1W 5% 100Ω ▲
R2506	ERG1FJ101P	METAL 1W 5% 100Ω ▲
R2507	ERD2FCVJ4R7P	CARBON 2W 5% 4R7Ω

Ref No.	Part No.	Description
R2508	ERW12PKR33	WOUND 0.5W 10% R33Ω ▲
R2509	ERD2FCVJ4R7P	CARBON 2W 5% 4R7Ω
R2510	TSF19252	FS LINK ▲
R2511	ERJ6GEY0R00	S.M.CARB 0.1W 5% 0Ω
R2512	ERJ6GEY0R00	S.M.CARB 0.1W 5% 0Ω
R2513	TSF19252	FS LINK ▲
R2514	TSF19632	FS LINK ▲
R2515	ERG3FJ470	METAL 3W 5% 47Ω ▲
R2516	ERG3FJ470	METAL 3W 5% 47Ω ▲
R2517	ERDS1TJ2R2	CARBON 0.5W 5% 2.2Ω
R2518	ERD25TJ101	CARBON 0.25W 5% 100Ω
R2519	ERD25TJ102	CARBON 0.25W 5% 1KΩ
R2520	ERDS1TJ103	CARBON 0.5W 5% 10KΩ
R2521	ERJ6GEYJ223	S.M.CARB 0.1W 5% 22KΩ
R2522	ERJ6GEYJ181	S.M.CARB 0.1W 5% 180Ω
R2523	ERG3FJ471	METAL 3W 5% 470Ω ▲
R2524	ERG3FJ471	METAL 3W 5% 470Ω ▲
R2525	ERJ6GEYJ822	S.M.CARB 0.1W 5% 8K2Ω
R2526	ERJ6GEY0R00	S.M.CARB 0.1W 5% 0Ω
R2527	ERJ6GEYJ2R2	S.M.CARB 0.125W 5% 2R2Ω
R2528	ERJ6GEYJ223	S.M.CARB 0.1W 5% 22KΩ
R2529	ERJ6GEYJ331	S.M.CARB 0.1W 5% 330Ω
R2530	ERJ6GEYJ123	S.M.CARB 0.1W 5% 12KΩ
R2531	ERJ6GEYJ153	S.M.CARB 0.1W 5% 15KΩ
R2532	ERJ6GEYJ2R2	S.M.CARB 0.125W 5% 2R2Ω
R2533	ERJ6GEYJ104	S.M.CARB 0.1W 5% 100KΩ
R2534	ERJ6GEYJ104	S.M.CARB 0.1W 5% 100KΩ
R2535	ERJ6GEYJ101	S.M.CARB 0.1W 5% 100Ω
R2536	ERJ6GEYJ101	S.M.CARB 0.1W 5% 100Ω
R2537	ERJ6GEYJ104	S.M.CARB 0.1W 5% 100KΩ
R2538	ERJ6GEYJ104	S.M.CARB 0.1W 5% 100KΩ
R2539	ERJ6GEYJ102	S.M.CARB 0.1W 5% 1KΩ
R2540	ERJ6GEYJ102	S.M.CARB 0.1W 5% 1KΩ
R2541	ERJ6GEYJ102	S.M.CARB 0.1W 5% 1KΩ
R2542	ERJ6GEYJ102	S.M.CARB 0.1W 5% 1KΩ
R2543	ERJ6GEYJ102	S.M.CARB 0.1W 5% 1KΩ
R2544	ERJ6GEYJ102	S.M.CARB 0.1W 5% 1KΩ
R2545	ERJ6GEYJ393	S.M.CARB 0.1W 5% 39KΩ
R2546	ERJ6GEYJ183	S.M.CARB 0.1W 5% 18KΩ
R2547	ERJ6GEYJ222	S.M.CARB 0.1W 5% 2K2Ω
R2548	ERJ6GEYJ221	S.M.CARB 0.1W 5% 220Ω
R2549	ERJ6GEYJ473	S.M.CARB 0.1W 5% 47KΩ
R2550	ERJ6GEYJ105	S.M.CARB 0.1W 5% 1MΩ
R2551	ERJ6GEYJ182	S.M.CARB 0.1W 5% 1K8Ω
R2552	ERJ6GEYJ104	S.M.CARB 0.1W 5% 100KΩ
R2553	ERJ6GEYJ104	S.M.CARB 0.1W 5% 100KΩ
R2554	ERJ6GEYJ472	S.M.CARB 0.1W 5% 4K7Ω
R2555	ERJ6GEYJ472	S.M.CARB 0.1W 5% 4K7Ω
R2556	ERJ6GEYJ103	S.M.CARB 0.1W 5% 10KΩ
R2557	ERJ6GEYJ103	S.M.CARB 0.1W 5% 10KΩ
R2558	ERJ6GEYJ103	S.M.CARB 0.1W 5% 10KΩ
R2559	ERJ6GEYJ103	S.M.CARB 0.1W 5% 10KΩ
R2560	ERJ6GEYJ472	S.M.CARB 0.1W 5% 4K7Ω
R2561	ERJ6GEYJ472	S.M.CARB 0.1W 5% 4K7Ω
R2562	ERJ6GEYJ104	S.M.CARB 0.1W 5% 100KΩ
R2563	ERJ6GEYJ104	S.M.CARB 0.1W 5% 100KΩ
R2564	ERJ6GEYJ333	S.M.CARB 0.1W 5% 33KΩ
R2565	ERJ6GEYJ153	S.M.CARB 0.1W 5% 15KΩ
R2566	ERJ6GEYJ224	S.M.CARB 0.1W 5% 220KΩ
R2568	ERJ6GEYJ102	S.M.CARB 0.1W 5% 1KΩ
R2569	ERJ6GEYJ223	S.M.CARB 0.1W 5% 22KΩ
R2570	ERJ6GEYJ104	S.M.CARB 0.1W 5% 100KΩ
R2571	ERJ6GEYJ104	S.M.CARB 0.1W 5% 100KΩ
R2572	ERJ6GEYJ472	S.M.CARB 0.1W 5% 4K7Ω
R2573	ERJ6GEYJ124	S.M.CARB 0.1W 5% 120KΩ
R2574	ERJ6GEYJ124	S.M.CARB 0.1W 5% 120KΩ
R2575	ERJ6GEYJ101	S.M.CARB 0.1W 5% 100Ω
R2576	ERJ6GEYJ101	S.M.CARB 0.1W 5% 100Ω
R2577	ERJ6GEYJ183	S.M.CARB 0.1W 5% 18KΩ
R2578	ERJ6GEYJ104	S.M.CARB 0.1W 5% 100KΩ
R2579	ERJ6GEYJ104	S.M.CARB 0.1W 5% 100KΩ

Ref No.	Part No.	Description
R2580	ERJ6GEYJ104	S.M.CARB 0.1W 5% 100KΩ
R2581	ERJ6GEYJ104	S.M.CARB 0.1W 5% 100KΩ
R2582	ERJ6GEYJ104	S.M.CARB 0.1W 5% 100KΩ
R2583	ERJ6GEYJ102	S.M.CARB 0.1W 5% 1KΩ
R2584	ERJ6GEYJ104	S.M.CARB 0.1W 5% 100KΩ
R2585	ERJ6GEYJ102	S.M.CARB 0.1W 5% 1KΩ
R2586	ERJ6GEYJ105	S.M.CARB 0.1W 5% 1MΩ
R2587	ERJ6GEYJ102	S.M.CARB 0.1W 5% 1KΩ
R2588	ERJ6GEYJ222	S.M.CARB 0.1W 5% 2K2Ω
R2589	ERJ6GEYJ392	S.M.CARB 0.1W 5% 3K9Ω
R2590	ERJ6GEYJ822	S.M.CARB 0.1W 5% 8K2Ω
R2591	ERJ6GEYJ153	S.M.CARB 0.1W 5% 15KΩ
R2592	ERJ6GEYJ333	S.M.CARB 0.1W 5% 33KΩ
R2593	ERJ6GEYJ683	S.M.CARB 0.1W 5% 68KΩ
R2594	ERJ6GEYJ124	S.M.CARB 0.1W 5% 120KΩ
R2595	ERJ6GEYJ271	S.M.CARB 0.1W 5% 270Ω
R2596	ERJ6GEYJ102	S.M.CARB 0.1W 5% 1KΩ
R2597	ERJ6GEYJ102	S.M.CARB 0.1W 5% 1KΩ
R2598	ERJ6GEYJ102	S.M.CARB 0.1W 5% 1KΩ
R2703	ERJ6GEYJ473	S.M.CARB 0.1W 5% 47KΩ
R2704	ERJ6GEYJ102	S.M.CARB 0.1W 5% 1KΩ
R2705	ERJ6GEY0R00	S.M.CARB 0.1W 5% 0Ω
R2801	ERJ6GEYJ473	S.M.CARB 0.1W 5% 47KΩ
R2802	ERJ6GEYJ103	S.M.CARB 0.1W 5% 10KΩ
R2803	ERJ6GEYJ103	S.M.CARB 0.1W 5% 10KΩ
R2804	ERJ6GEYJ104	S.M.CARB 0.1W 5% 100KΩ
R2805	ERJ6GEYJ563	S.M.CARB 0.1W 5% 56KΩ
R2806	ERJ6GEYJ474	S.M.CARB 0.1W 5% 470KΩ
R2807	ERJ6GEYJ104	S.M.CARB 0.1W 5% 100KΩ
R2808	ERJ6GEYJ563	S.M.CARB 0.1W 5% 56KΩ
R2809	ERJ6GEYJ474	S.M.CARB 0.1W 5% 470KΩ
R2810	ERJ6GEYJ474	S.M.CARB 0.1W 5% 470KΩ
R2811	ERJ6GEYJ563	S.M.CARB 0.1W 5% 56KΩ
R2812	ERJ6GEYJ104	S.M.CARB 0.1W 5% 100KΩ
R2813	ERJ6GEYJ104	S.M.CARB 0.1W 5% 100KΩ
R2814	ERJ6GEYJ474	S.M.CARB 0.1W 5% 470KΩ
R2815	ERJ6GEYJ563	S.M.CARB 0.1W 5% 56KΩ
R2816	ERJ6GEYJ102	S.M.CARB 0.1W 5% 1KΩ
R2817	ERJ6GEYJ473	S.M.CARB 0.1W 5% 47KΩ
R2818	ERJ6GEYJ102	S.M.CARB 0.1W 5% 1KΩ
R2819	ERJ6GEYJ473	S.M.CARB 0.1W 5% 47KΩ
R2820	ERJ6GEYJ102	S.M.CARB 0.1W 5% 1KΩ
R2821	ERJ6GEYJ473	S.M.CARB 0.1W 5% 47KΩ
R2822	ERJ6GEYJ102	S.M.CARB 0.1W 5% 1KΩ
R2823	ERJ6GEYJ473	S.M.CARB 0.1W 5% 47KΩ
R3101	ERJ6GEYJ562	S.M.CARB 0.1W 5% 5K6Ω
R3102	ERJ6GEYJ562	S.M.CARB 0.1W 5% 5K6Ω
R3103	ERJ6GEYJ562	S.M.CARB 0.1W 5% 5K6Ω
R3104	ERJ6GEYJ222	S.M.CARB 0.1W 5% 2K2Ω
R3106	ERJ6GEYJ563	S.M.CARB 0.1W 5% 56KΩ
R3107	ERJ6GEYJ472	S.M.CARB 0.1W 5% 4K7Ω
R3108	ERJ6GEYJ471	S.M.CARB 0.1W 5% 470Ω
R3109	ERJ6GEYJ101	S.M.CARB 0.1W 5% 100Ω
R3111	ERDS1FYJ222	CARBON 0.5W 5% 2K2Ω ▲
R3112	ERJ6GEYJ152	S.M.CARB 0.1W 5% 1K5Ω
R3113	ERD25TJ681	CARBON 0.25W 5% 680Ω
R3121	ERJ6GEYJ153	S.M.CARB 0.1W 5% 15KΩ
R3122	ERJ6GEYJ222	S.M.CARB 0.1W 5% 2K2Ω
R3123	ERJ6GEYJ471	S.M.CARB 0.1W 5% 470Ω
R3124	ERJ6GEYJ681	S.M.CARB 0.1W 5% 680Ω
R3126	ERJ6GEYJ182	S.M.CARB 0.1W 5% 1K8Ω
R3127	ERQ14AJ100	METAL 0.25W 5% 10Ω ▲
R3128	ERQ14AJ820	METAL 0.25W 5% 82Ω ▲
R3129	ERQ14AJ820	METAL 0.25W 5% 82Ω ▲
R3130	ERJ6GEYJ100	S.M.CARB 0.1W 5% 10Ω
R3131	ERD25TJ563	CARBON 0.25W 5% 56KΩ
R3132	ERD25TJ122	CARBON 0.25W 5% 1K2Ω
R3133	ERD25TJ2R7	CARBON 0.25W 5% 2R7Ω
R3134	ERDS1FVJ390	CARBON 0.5W 5% 39Ω ▲
R3135	ERJ6GEYJ100	S.M.CARB 0.1W 5% 10Ω
R3136	ERD25TJ563	CARBON 0.25W 5% 56KΩ
R3137	ERD25TJ122	CARBON 0.25W 5% 1K2Ω

Ref No.	Part No.	Description
R3138	ERD25TJ2R7	CARBON 0.25W 5% 2R7Ω
R3139	ERDS1FVJ390	CARBON 0.5W 5% 39Ω ▲
R3141	ERDS1FYJ101	CARBON 0.5W 5% 100Ω ▲
R3142	ERJ6GEYJ472	S.M.CARB 0.1W 5% 4K7Ω
R3143	ERJ6GEYJ222	S.M.CARB 0.1W 5% 2K2Ω
R3144	ERJ6GEYJ681	S.M.CARB 0.1W 5% 680Ω
R3146	ERDS1FYJ181	CARBON 0.5W 5% 180Ω ▲
R3152	ERQ12HJ102	METAL 0.5W 5% 1KΩ ▲
R3153	ERQ14AJ3R9	FUSIBLE 0.25W 5% 3R9Ω ▲
R3160	ERJ6GEYJ100	S.M.CARB 0.1W 5% 10Ω
R3161	ERJ6GEYJ102	S.M.CARB 0.1W 5% 1KΩ
R3162	ERJ6GEYJ102	S.M.CARB 0.1W 5% 1KΩ
R3163	ERJ6GEYJ332	S.M.CARB 0.1W 5% 3K3Ω
R3164	ERJ6GEYJ471	S.M.CARB 0.1W 5% 470Ω
R3166	ERJ6GEYJ471	S.M.CARB 0.1W 5% 470Ω
R3167	ERJ6GEYJ471	S.M.CARB 0.1W 5% 470Ω
R3168	ERJ6GEYJ102	S.M.CARB 0.1W 5% 1KΩ
R3169	ERJ6GEYJ122	S.M.CARB 0.1W 5% 1K2Ω
R3170	ERJ6GEYJ100	S.M.CARB 0.1W 5% 10Ω
R3171	ERJ6GEYJ102	S.M.CARB 0.1W 5% 1KΩ
R3172	ERJ6GEYJ102	S.M.CARB 0.1W 5% 1KΩ
R3173	ERJ6GEYJ332	S.M.CARB 0.1W 5% 3K3Ω
R3174	ERJ6GEYJ471	S.M.CARB 0.1W 5% 470Ω
R3176	ERJ6GEYJ471	S.M.CARB 0.1W 5% 470Ω
R3177	ERJ6GEYJ471	S.M.CARB 0.1W 5% 470Ω
R3178	ERJ6GEYJ102	S.M.CARB 0.1W 5% 1KΩ
R3179	ERJ6GEYJ122	S.M.CARB 0.1W 5% 1K2Ω
R3180	ERJ6GEYJ100	S.M.CARB 0.1W 5% 10Ω
R3181	ERJ6GEYJ102	S.M.CARB 0.1W 5% 1KΩ
R3182	ERJ6GEYJ102	S.M.CARB 0.1W 5% 1KΩ
R3183	ERJ6GEYJ332	S.M.CARB 0.1W 5% 3K3Ω
R3184	ERJ6GEYJ471	S.M.CARB 0.1W 5% 470Ω
R3186	ERJ6GEYJ471	S.M.CARB 0.1W 5% 470Ω
R3187	ERJ6GEYJ471	S.M.CARB 0.1W 5% 470Ω
R3188	ERJ6GEYJ102	S.M.CARB 0.1W 5% 1KΩ
R3189	ERJ6GEYJ122	S.M.CARB 0.1W 5% 1K2Ω
R3307	ERJ6GEYJ101	S.M.CARB 0.1W 5% 100Ω
R3308	ERJ6GEYJ101	S.M.CARB 0.1W 5% 100Ω
R3309	ERJ6GEYJ101	S.M.CARB 0.1W 5% 100Ω
R3354	ERJ6GEYJ473	S.M.CARB 0.1W 5% 47KΩ
R3358	ERJ6GEYJ100	S.M.CARB 0.1W 5% 10Ω
R3359	ERJ6GEYJ472	S.M.CARB 0.1W 5% 4K7Ω
R3361	ERQ12HKR39	METAL 0.5W 5% R39Ω ▲
R3362	ERC12GK105D	SOLID 0.5W 10% 1MΩ
R3364	ERC12GK821D	SOLID 0.5W 10% 820Ω
R3365	ERD25TJ220	CARBON 0.25W 5% 22Ω
R3366	ERQ12AJ101	FUSIBLE 0.5W 5% 100Ω ▲
R3367	ERJ6GEYJ102	S.M.CARB 0.1W 5% 1KΩ
R3368	ERJ6GEYJ103	S.M.CARB 0.1W 5% 10KΩ
R3369	ERJ6GEYJ682	S.M.CARB 0.1W 5% 6K8Ω
R3370	ERJ6GEYJ100	S.M.CARB 0.1W 5% 10Ω
R3371	ERJ6GEYJ272	S.M.CARB 0.1W 5% 2K7Ω
R3372	ERJ6GEYJ332	S.M.CARB 0.1W 5% 3K3Ω
R3373	ERJ6GEYJ152	S.M.CARB 0.1W 5% 1K5Ω
R3374	ERDS1TJ913	CARBON 0.5W 5% 91KΩ
R3375	ERG2ANJ183	METAL 2W 5% 18KΩ
R3376	ERD25TJ561	CARBON 0.25W 5% 560Ω
R3377	ERJ6GEY0R00	S.M.CARB 0.1W 5% 0Ω
R3378	ERC12GK332V	SOLID 0.5W 10% 3K3Ω
R3379	ERD25TJ103	CARBON 0.25W 5% 10KΩ
R3380	ERJ6GEYJ100	S.M.CARB 0.1W 5% 10Ω
R3381	ERJ6GEYJ272	S.M.CARB 0.1W 5% 2K7Ω
R3382	ERJ6GEYJ332	S.M.CARB 0.1W 5% 3K3Ω
R3383	ERJ6GEYJ152	S.M.CARB 0.1W 5% 1K5Ω
R3384	ERDS1TJ913	CARBON 0.5W 5% 91KΩ
R3385	ERG2ANJ183	METAL 2W 5% 18KΩ
R3386	ERD25TJ561	CARBON 0.25W 5% 560Ω
R3388	ERC12GK332V	SOLID 0.5W 10% 3K3Ω
R3389	ERD25TJ103	CARBON 0.25W 5% 10KΩ
R3390	ERJ6GEYJ100	S.M.CARB 0.1W 5% 10Ω
R3391	ERJ6GEYJ272	S.M.CARB 0.1W 5% 2K7Ω
R3392	ERJ6GEYJ332	S.M.CARB 0.1W 5% 3K3Ω

Ref No.	Part No.	Description
R3393	ERJ6GEYJ152	S.M.CARB 0.1W 5% 1K5Ω
R3394	ERDS1TJ913	CARBON 0.5W 5% 91KΩ
R3395	ERG2ANJ183	METAL 2W 5% 18KΩ
R3396	ERD25TJ561	CARBON 0.25W 5% 560Ω
R3398	ERC12GK332V	SOLID 0.5W 10% 3K3Ω
R3399	ERD25TJ103	CARBON 0.25W 5% 10KΩ
R4701	ERJ6GEYJ222	S.M.CARB 0.1W 5% 2K2Ω
R4702	ERJ6GEYJ102	S.M.CARB 0.1W 5% 1KΩ
R4703	ERJ6GEYJ562	S.M.CARB 0.1W 5% 5K6Ω
R4705	ERJ6GEY0R00	S.M.CARB 0.1W 5% 0Ω
R4707	ERJ6GEYJ683	S.M.CARB 0.1W 5% 68KΩ
R4708	ERJ6GEYJ153	S.M.CARB 0.1W 5% 15KΩ
R4709	ERJ6GEYJ102	S.M.CARB 0.1W 5% 1KΩ
R4710	ERJ6GEYJ181	S.M.CARB 0.1W 5% 180Ω
R4711	ERJ6GEYJ121	S.M.CARB 0.1W 5% 120Ω
R4713	ERJ6GEYJ222	S.M.CARB 0.1W 5% 2K2Ω
R4714	ERJ6GEYJ471	S.M.CARB 0.1W 5% 470Ω
R4715	ERJ6GEYJ681	S.M.CARB 0.1W 5% 680Ω
R4716	ERJ6GEYJ222	S.M.CARB 0.1W 5% 2K2Ω
R4717	ERJ6GEYJ332	S.M.CARB 0.1W 5% 3K3Ω
R4718	ERJ6GEYJ103	S.M.CARB 0.1W 5% 10KΩ
R4719	ERJ6GEYJ333	S.M.CARB 0.1W 5% 33KΩ
R4720	ERJ6GEYJ682	S.M.CARB 0.1W 5% 6K8Ω
R4721	ERJ6GEYJ332	S.M.CARB 0.1W 5% 3K3Ω
R4722	ERJ6GEYJ103	S.M.CARB 0.1W 5% 10KΩ
R4726	ERJ6GEYJ103	S.M.CARB 0.1W 5% 10KΩ
R4727	ERJ6GEYJ103	S.M.CARB 0.1W 5% 10KΩ
R4728	ERJ6GEYJ103	S.M.CARB 0.1W 5% 10KΩ
R4729	ERJ6GEYJ103	S.M.CARB 0.1W 5% 10KΩ
R4730	ERJ6GEY0R00	S.M.CARB 0.1W 5% 0Ω
R4735	ERJ6GEYJ331	S.M.CARB 0.1W 5% 330Ω
R4736	ERJ6GEYJ331	S.M.CARB 0.1W 5% 330Ω
R4737	ERJ6GEYJ103	S.M.CARB 0.1W 5% 10KΩ
R4738	ERJ6GEY0R00	S.M.CARB 0.1W 5% 0Ω
R4739	ERJ6GEYJ103	S.M.CARB 0.1W 5% 10KΩ
R4743	ERJ6GEYJ682	S.M.CARB 0.1W 5% 6K8Ω
R4744	ERJ6GEYJ221	S.M.CARB 0.1W 5% 220Ω
R4745	ERJ6GEY0R00	S.M.CARB 0.1W 5% 0Ω
R4746	ERJ6GEYJ103	S.M.CARB 0.1W 5% 10KΩ
R4747	ERJ6GEY0R00	S.M.CARB 0.1W 5% 0Ω
R4748	ERJ6GEY0R00	S.M.CARB 0.1W 5% 0Ω
R4750	ERJ6GEYJ473	S.M.CARB 0.1W 5% 47KΩ
R4751	ERJ6GEYJ563	S.M.CARB 0.1W 5% 56KΩ
R4752	ERJ6GEYJ102	S.M.CARB 0.1W 5% 1KΩ
R4753	ERJ6GEYJ121	S.M.CARB 0.1W 5% 120Ω
R4754	ERJ6GEYJ271	S.M.CARB 0.1W 5% 270Ω
R4755	ERJ6GEYJ101	S.M.CARB 0.1W 5% 100Ω
R4756	ERJ6GEYJ332	S.M.CARB 0.1W 5% 3K3Ω
R4757	ERJ6GEYJ122	S.M.CARB 0.1W 5% 1K2Ω
R4758	ERJ6GEY0R00	S.M.CARB 0.1W 5% 0Ω
R4759	ERJ6GEY0R00	S.M.CARB 0.1W 5% 0Ω
R4760	ERJ6GEYJ121	S.M.CARB 0.1W 5% 120Ω
R4771	ERJ6GEY0R00	S.M.CARB 0.1W 5% 0Ω
R6102	ERD25TJ151	CARBON 0.25W 5% 150Ω
R6106	ERD25TJ330	CARBON 0.25W 5% 33Ω
R6111	ERJ6GEYJ103	S.M.CARB 0.1W 5% 10KΩ
R6112	ERJ6GEYJ103	S.M.CARB 0.1W 5% 10KΩ
R6113	ERJ6GEYJ472	S.M.CARB 0.1W 5% 4K7Ω
R6114	ERJ6GEYJ102	S.M.CARB 0.1W 5% 1KΩ
R6301	ERJ6GEYJ101	S.M.CARB 0.1W 5% 100Ω
R6302	ERJ6GEYJ101	S.M.CARB 0.1W 5% 100Ω
R6305	ERJ6GEY0R00	S.M.CARB 0.1W 5% 0Ω
R6401	ERD25TJ220	CARBON 0.25W 5% 22Ω

Ref No.	Part No.	Description
R6402	ERD25TJ220	CARBON 0.25W 5% 22Ω
R6403	ERJ6GEYJ102	S.M.CARB 0.1W 5% 1KΩ
R6404	ERJ6GEY0R00	S.M.CARB 0.1W 5% 0Ω
R6405	ERJ6GEY0R00	S.M.CARB 0.1W 5% 0Ω
R6406	ERJ6GEYJ102	S.M.CARB 0.1W 5% 1KΩ
R6407	ERJ6GEYJ472	S.M.CARB 0.1W 5% 4K7Ω
R6408	ERJ6GEY0R00	S.M.CARB 0.1W 5% 0Ω
R6411	ERJ6GEYJ473	S.M.CARB 0.1W 5% 47KΩ
R6412	ERJ6GEYJ273	S.M.CARB 0.1W 5% 27KΩ
R6413	ERJ6GEYJ102	S.M.CARB 0.1W 5% 1KΩ
R6416	ERD25TJ101	CARBON 0.25W 5% 100Ω
R6417	ERD25TJ101	CARBON 0.25W 5% 100Ω
R6418	ERJ6GEYJ100	S.M.CARB 0.1W 5% 10Ω
R6433	ERJ6GEYJ102	S.M.CARB 0.1W 5% 1KΩ
R6436	ERJ6GEYJ102	S.M.CARB 0.1W 5% 1KΩ
R6437	ERJ6GEYJ472	S.M.CARB 0.1W 5% 4K7Ω
R6438	ERJ6GEY0R00	S.M.CARB 0.1W 5% 0Ω
R6441	ERJ6GEYJ473	S.M.CARB 0.1W 5% 47KΩ
R6442	ERJ6GEYJ273	S.M.CARB 0.1W 5% 27KΩ
R6443	ERJ6GEYJ102	S.M.CARB 0.1W 5% 1KΩ
R6446	ERD25TJ101	CARBON 0.25W 5% 100Ω
R6447	ERD25TJ101	CARBON 0.25W 5% 100Ω
R6448	ERJ6GEYJ100	S.M.CARB 0.1W 5% 10Ω
R6811	ERC12ZGK335D	SOLID 0.5W 10% 3M3Ω

SWITCHES

S6304	EVQ23405R	SWITCH
S6305	EVQ23405R	SWITCH
S6306	EVQ23405R	SWITCH
S6307	EVQ23405R	SWITCH
S6308	EVQ23405R	SWITCH
S6811	ESB91232A	SWITCH

▲

TRANSFORMERS

T528	ETH19Y173AY	TRANSFORMER
T531	ZTFH65005A	TRANSFORMER
T639	ETS39AH127AC	TRANSFORMER
T2502	ETS35AA3J7AC	TRANSFORMER
T6101	ETP35KAN614U	TRANSFORMER

▲

▲

CONNECTORS

W1951	MKS165810808	CONNECTOR
-------	--------------	-----------

FILTERS



X1321	4730007158	CRYSTAL
X1608	TSS2169-B	CRYSTAL
X1854	TSS4007-B	CRYSTAL
X2501	TAF10059	CRYSTAL
X2502	TAFCSA4.00MG	CRYSTAL
X4702	EFCV4155A3	CERAMIC FILTER
X4704	J3352K	SAW FILTER
X4706	EFC56R0MW5	FILTER



SCHEMATIC DIAGRAM FOR MODEL TX-29AD2DP/M (EURO-2S CHASSIS)

IMPORTANT SAFETY NOTICE

Components identified by  mark have special characteristics important for safety. When replacing any of these components, use only manufacturer's specified parts.

Notes

1. **RESISTOR**
All resistors are carbon 1/4W resistor, unless marked.
Unit of resistance is OHM (Ω) (K=1,000, M=1,000,000).
2. **CAPACITOR**
All capacitors are ceramic 50V capacitors, unless marked, the unit of capacitance is μ F unless otherwise stated.
3. **COIL**
Unit of inductance is μ H, unless otherwise stated.
4. **TEST POINT**
 : Test Point position
5. **EARTH SYMBOL**
 : Chassis Earth (Cold)
 : Line Earth (Hot)
6. **VOLTAGE MEASUREMENT**
Voltage is measured by a DC voltmeter.
Measurement conditions are as follows:

Power source	AC 220-240V, 50Hz
Receiving Signal	Colour Bar signal (RF)
All customer controls	Maximum position
7.
 : Indicates the Video signal path
 : Indicates the Audio signal path
 : Indicates the Vertical/Horizontal signal path
8. This schematic diagram is the latest at the time of printing and is subject to change without notice.

Precautions

- a. Do not touch the hot part, or the hot and cold parts at the same time, as you are liable to a shock hazard.
- b. Do not short-circuit the hot and cold circuits as electrical components may be damaged.
- c. Do not connect an instrument, such as an oscilloscope, to the hot and cold circuits simultaneously, as this may cause fuse failure. Connect the earth of the instruments to the earth connection of the circuit being measured.
- d. Make sure to disconnect the power plug before removing the chassis.

Remarks

1. The Power Circuit contains a circuit area which uses a separate power supply to isolate the earth connection. The circuit is defined by HOT and COLD indications in the schematic diagram. All circuits, except the Power Circuit, are COLD.

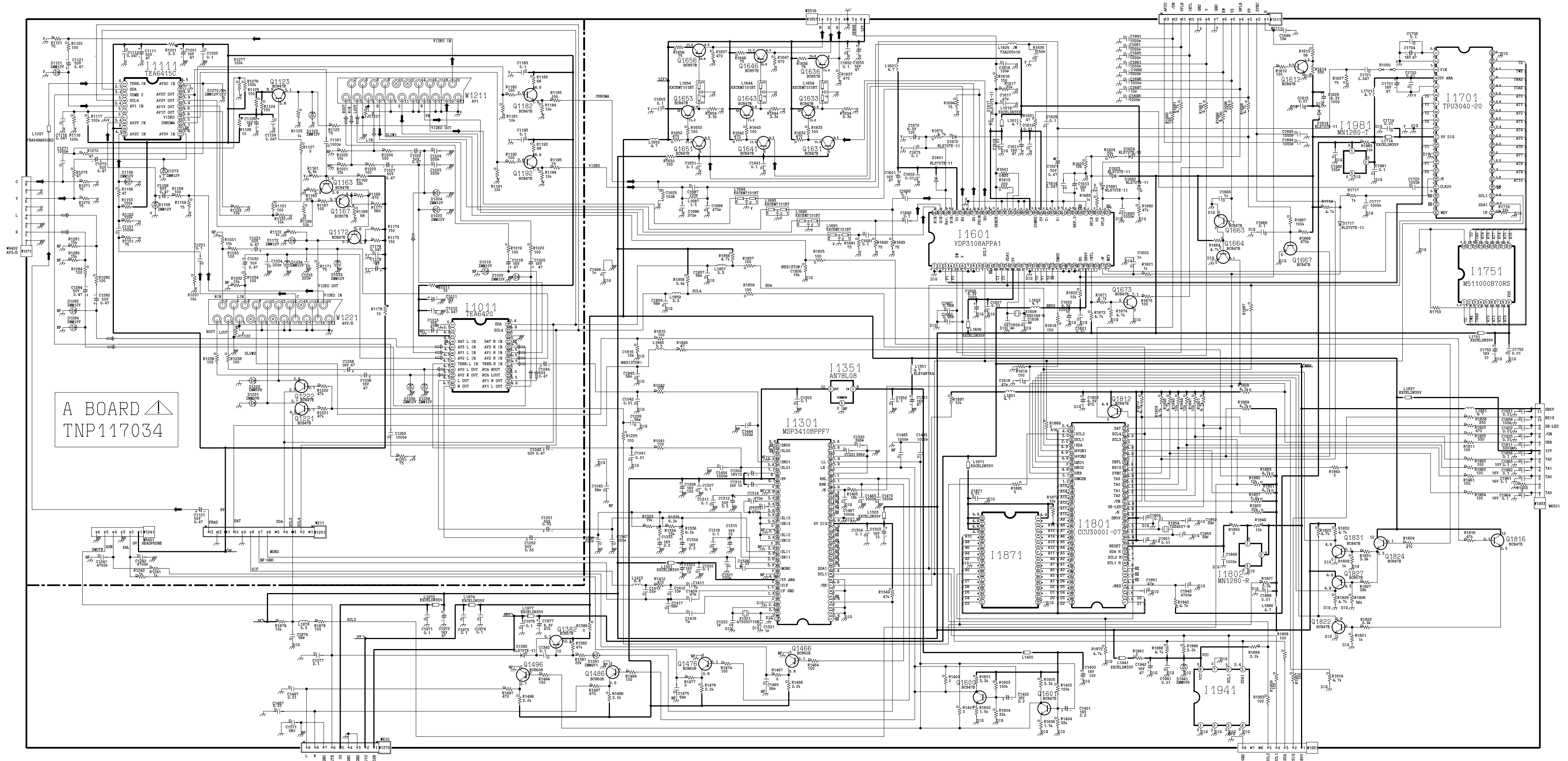

A BOARD
TNP117034

B BOARD
TNP117039

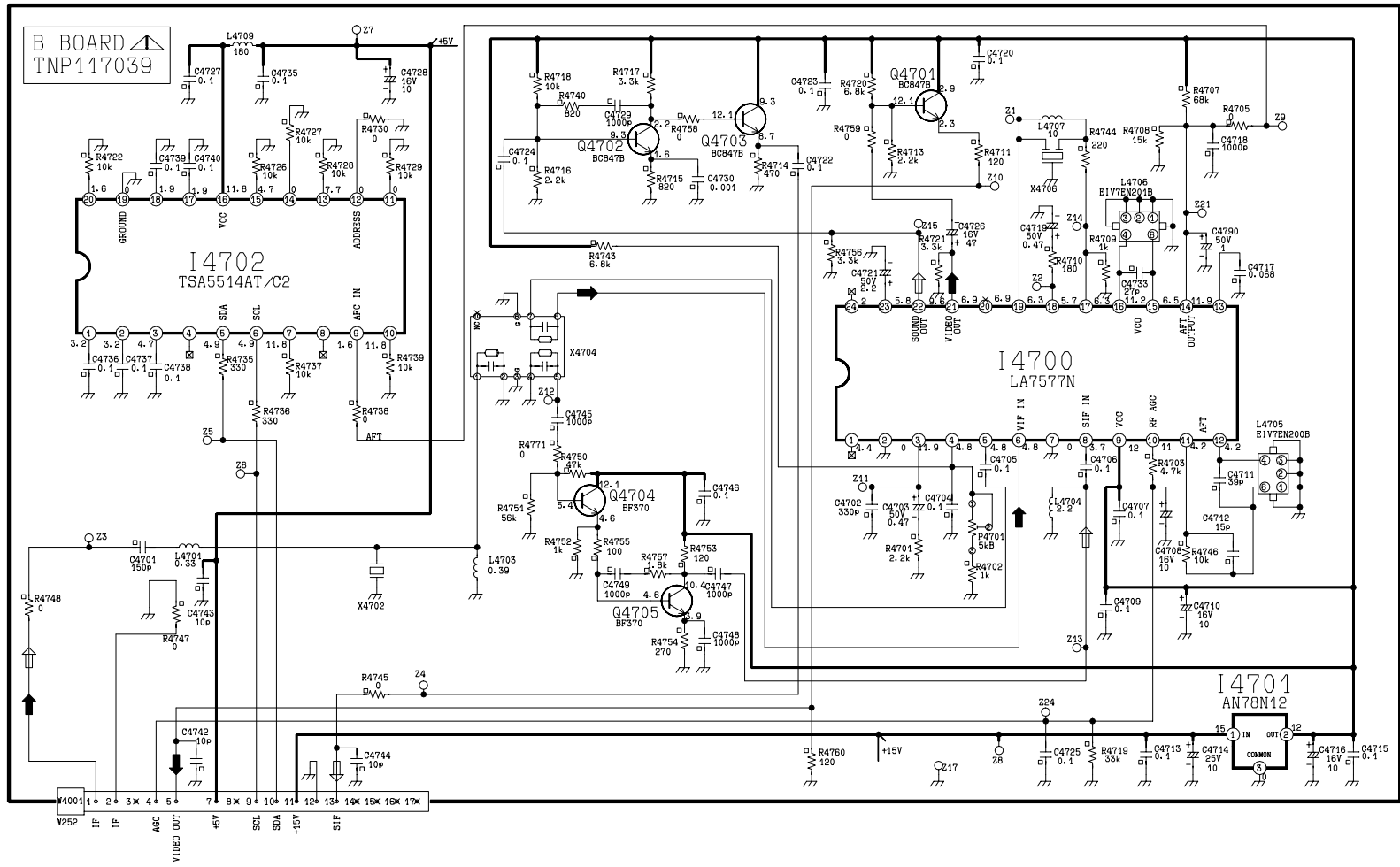

C BOARD ⚠
TNP8EC002

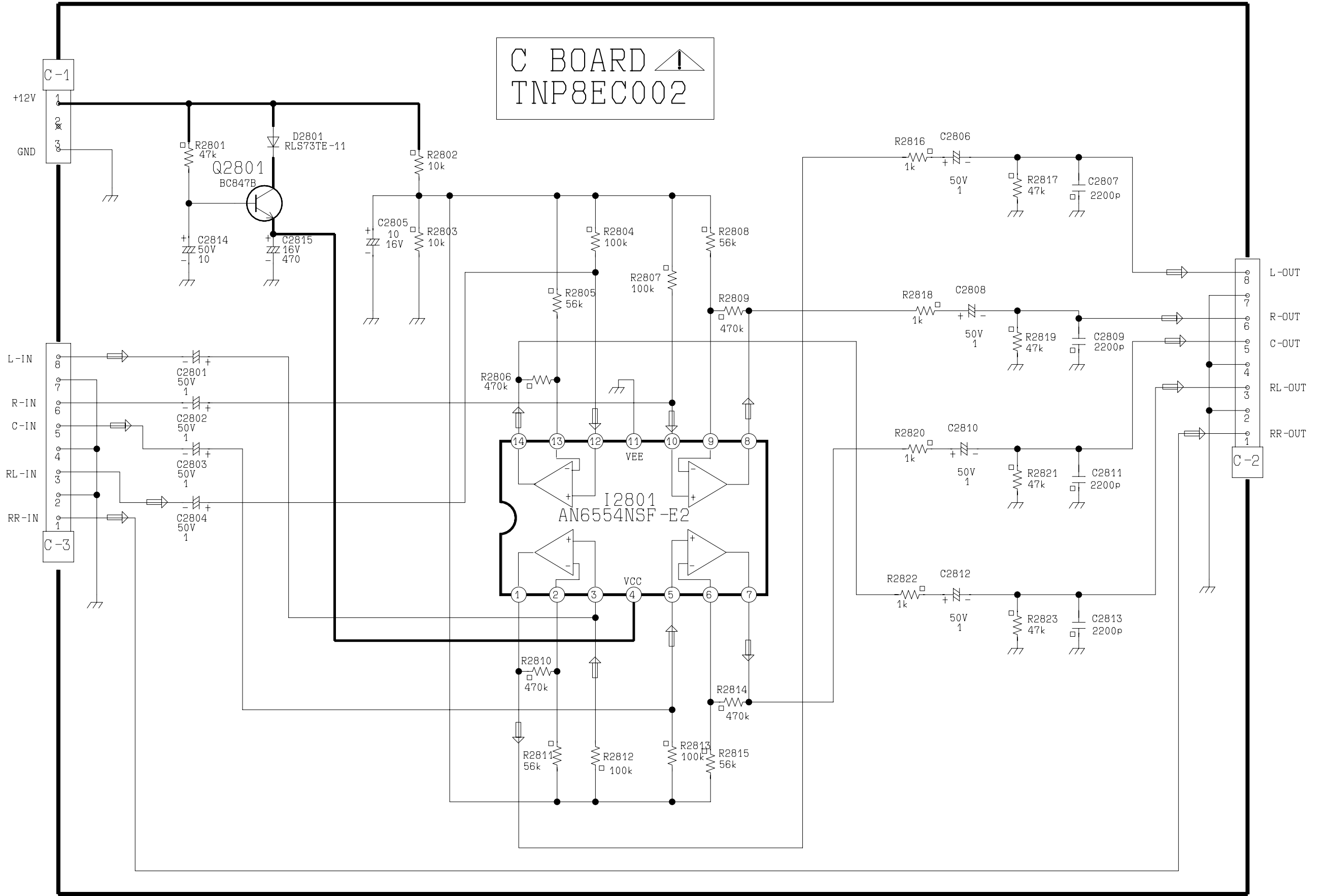

E BOARD TNP197087

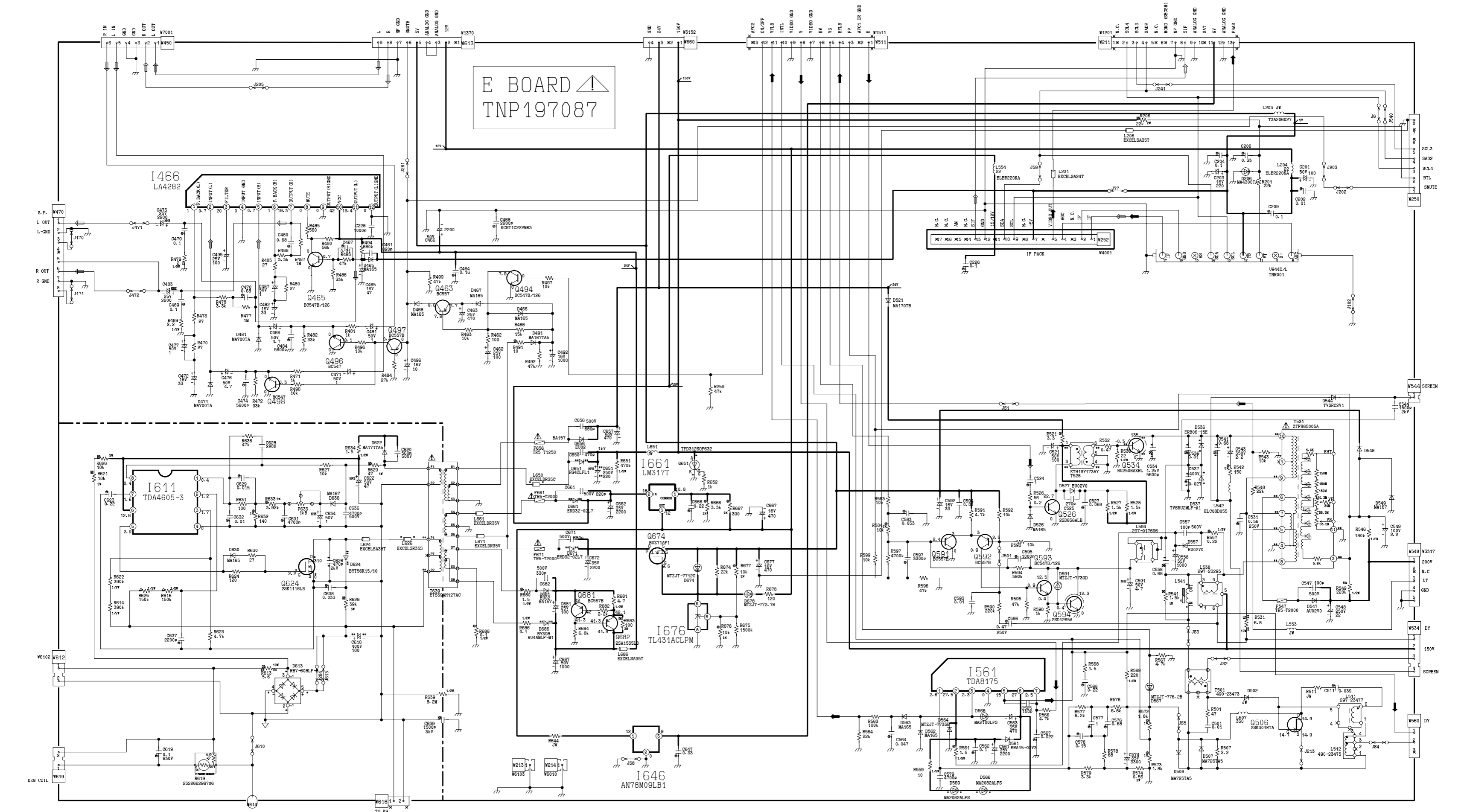

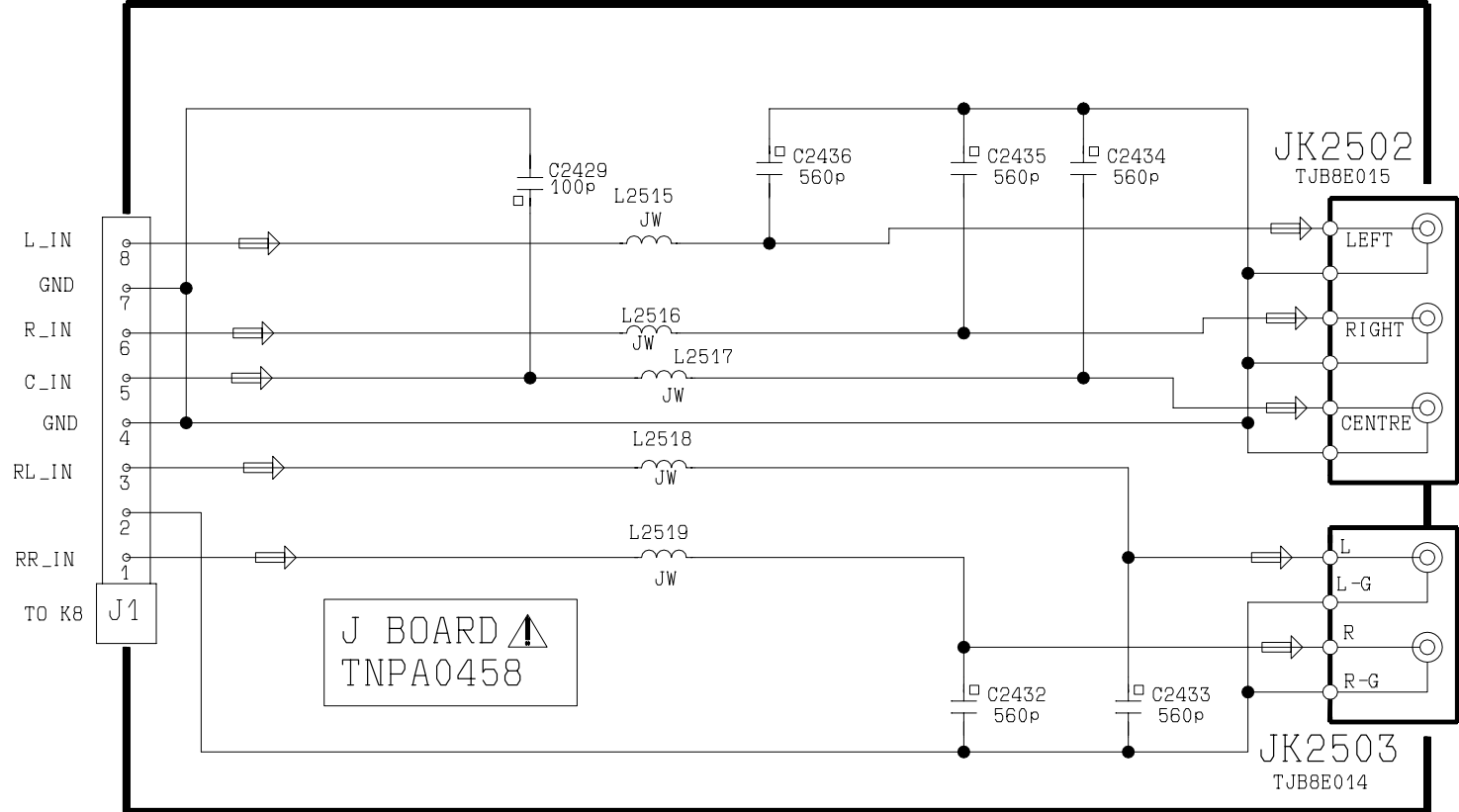

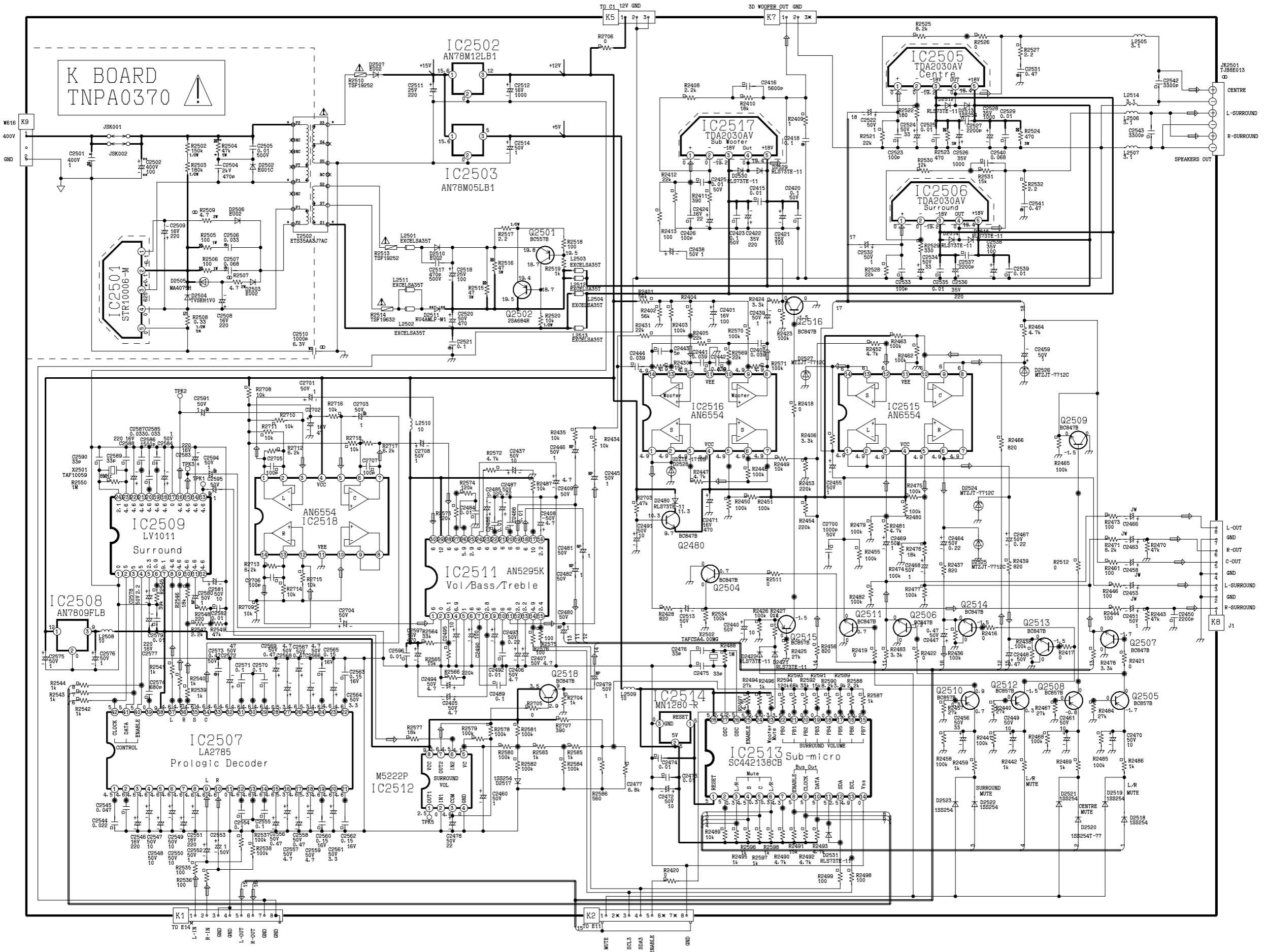

M BOARD
TNP8EM012

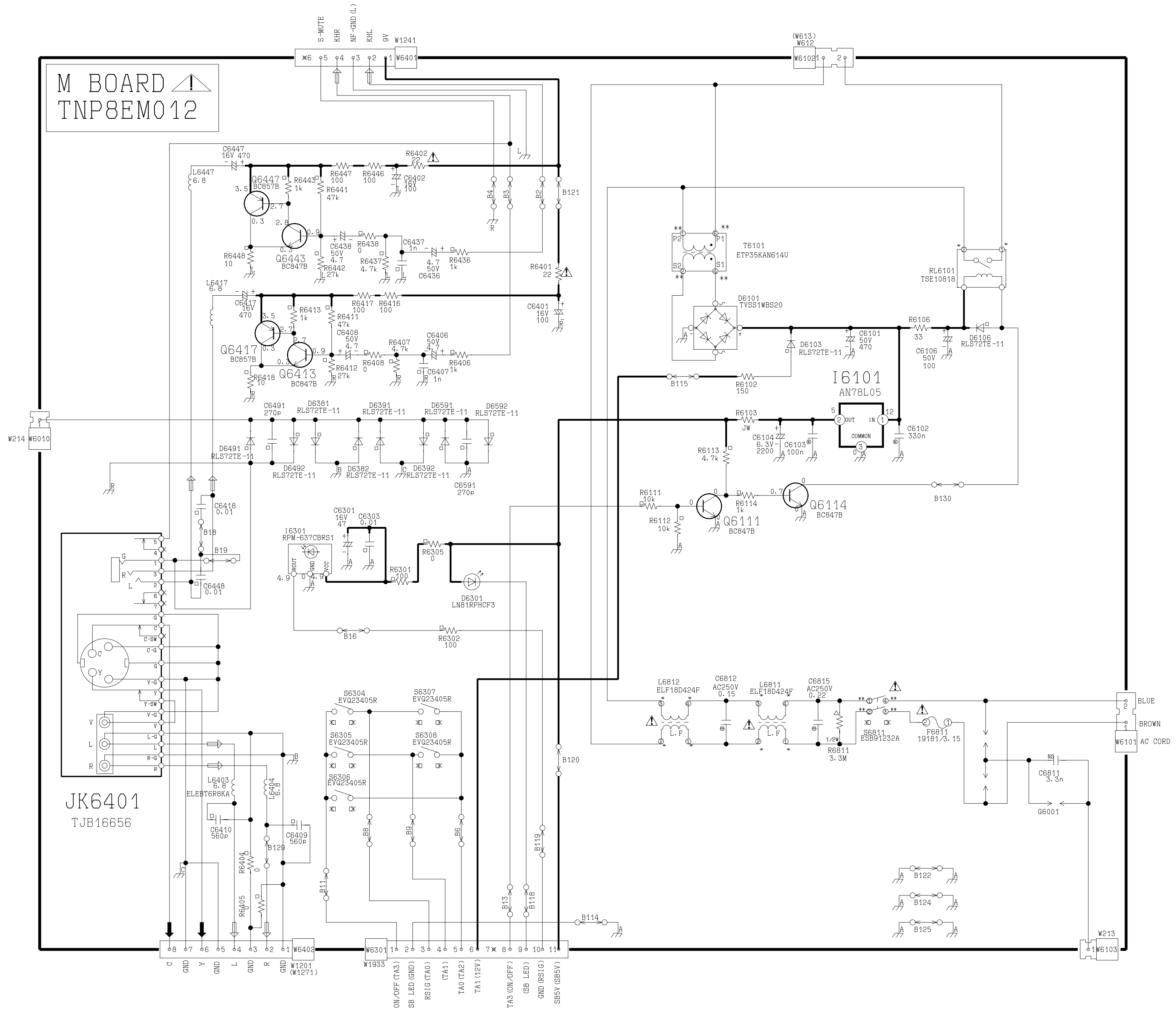

JK6401
TJB16656

BLUE
BROWN
W6101 AC CORD

Y BOARD TNP117037

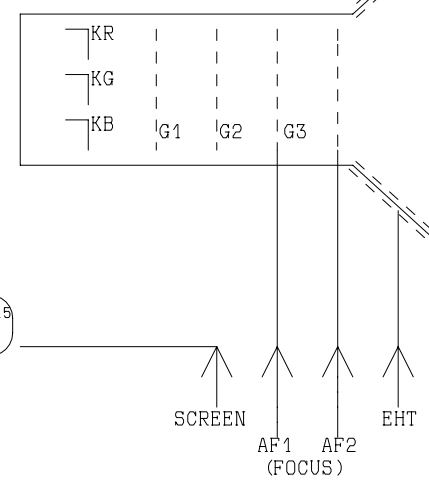
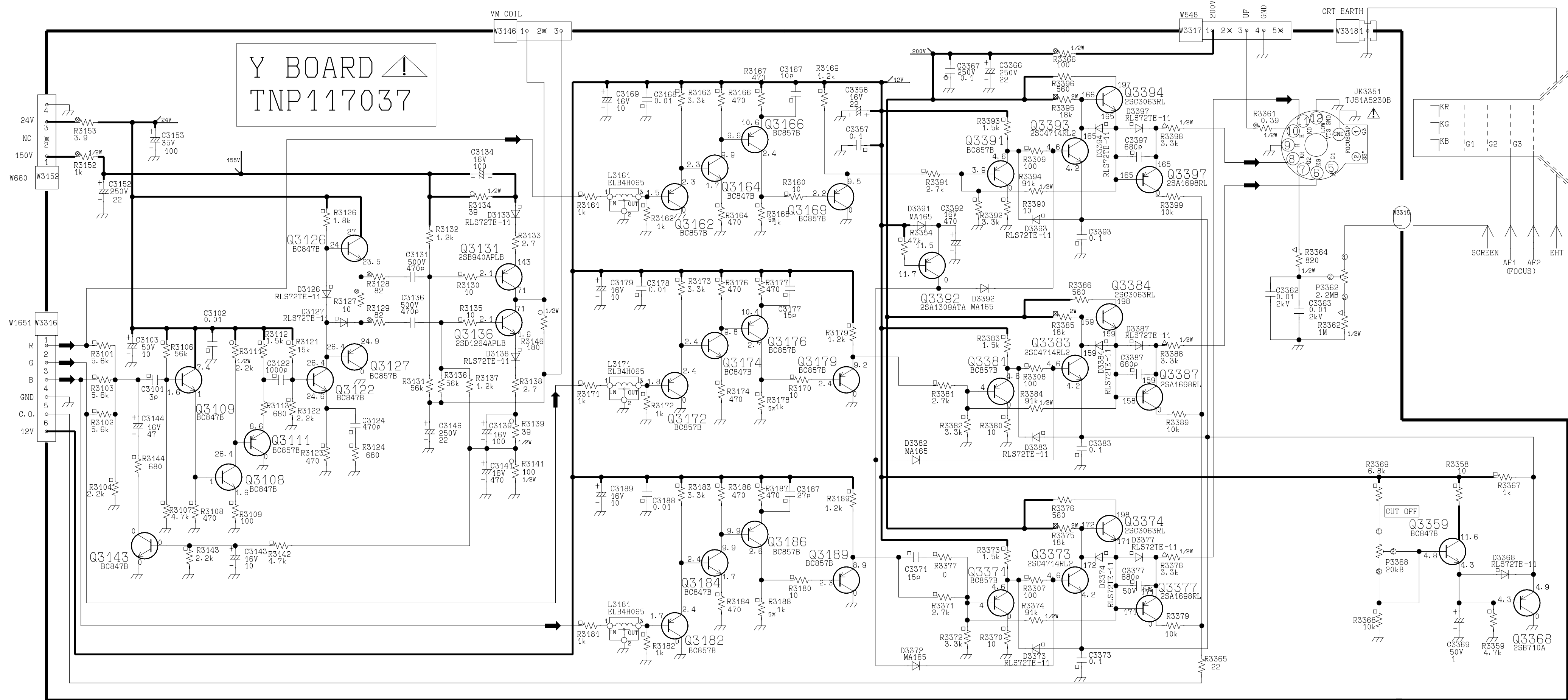

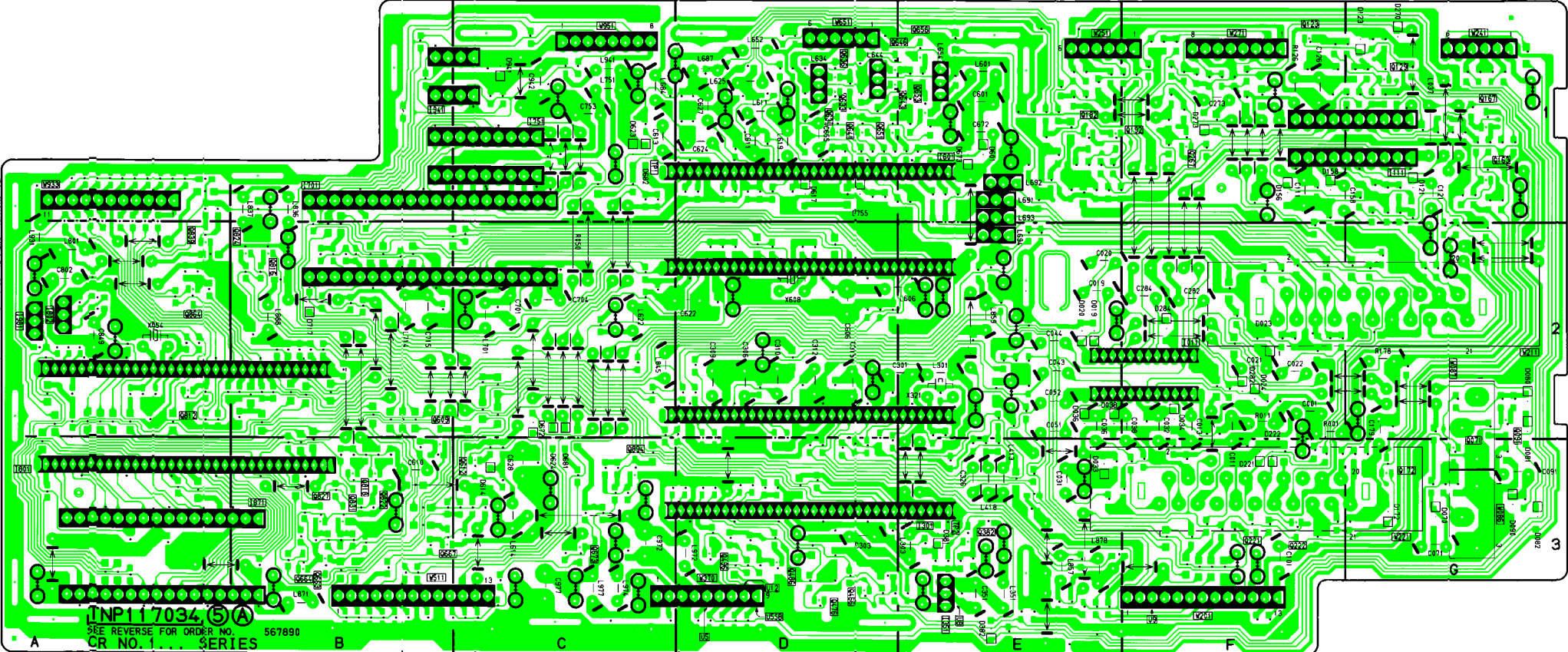

INP117034
SEE REVERSE FOR ORDER NO. 567890
CR NO. 1... SERIES

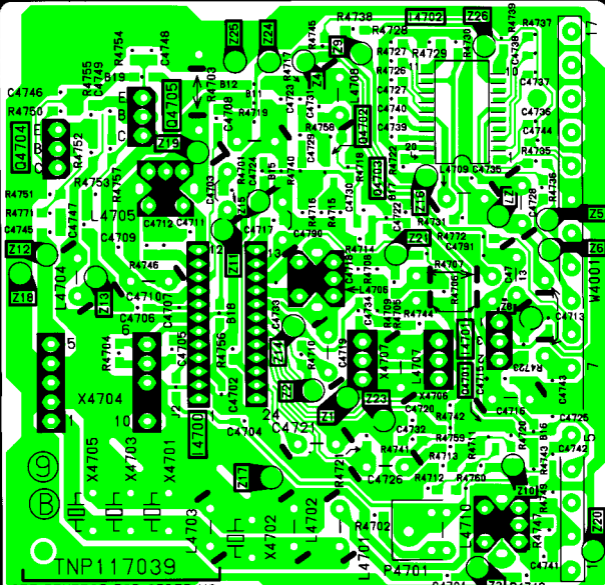

TNP117039

SEE REVERSE FOR ORDER NO.

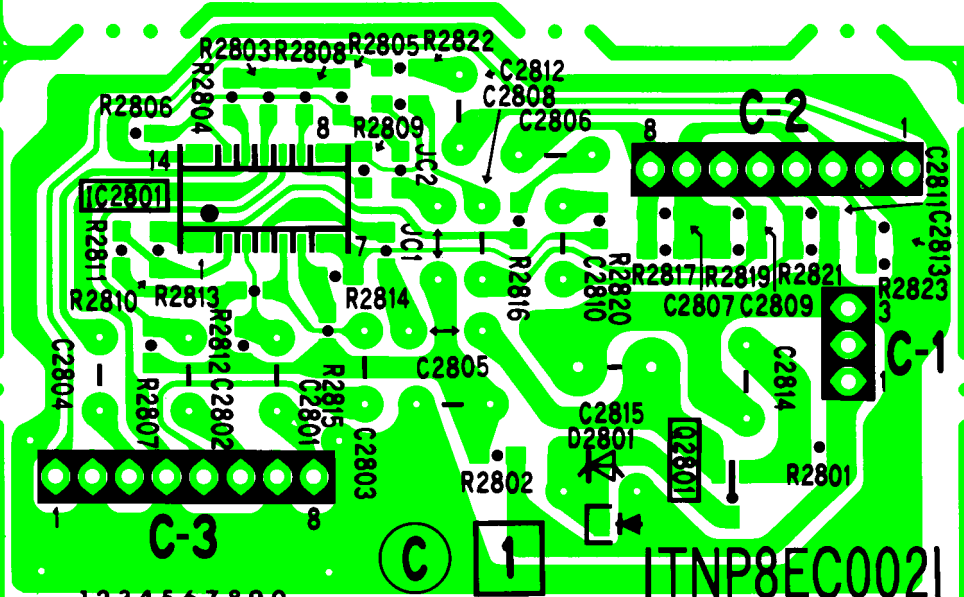

1 2 3 4 5 6 7 8 9 0

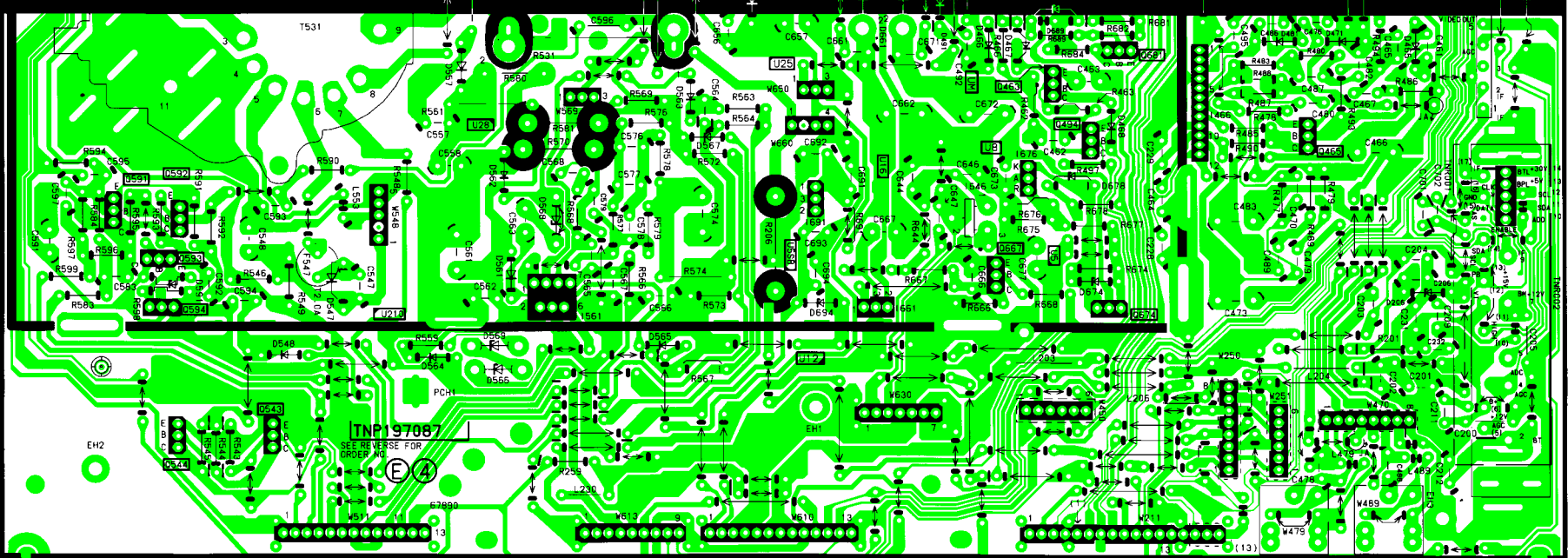
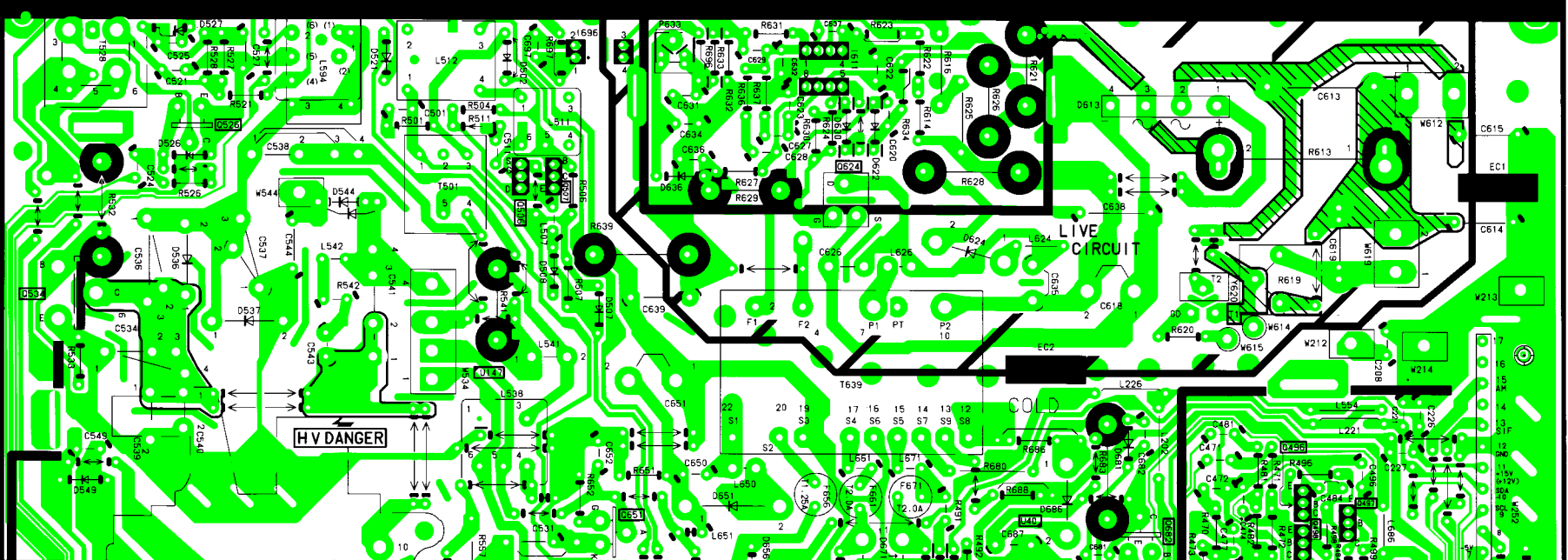

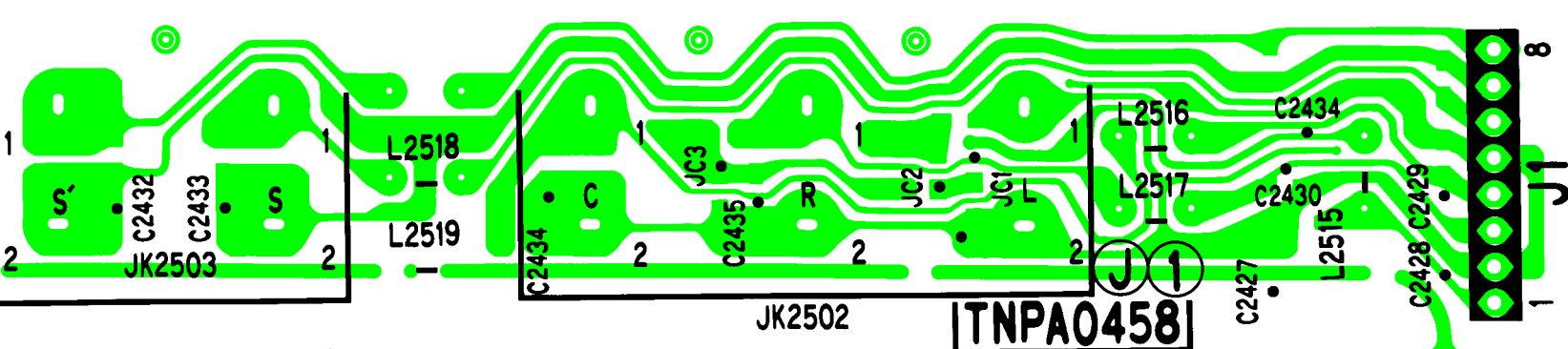

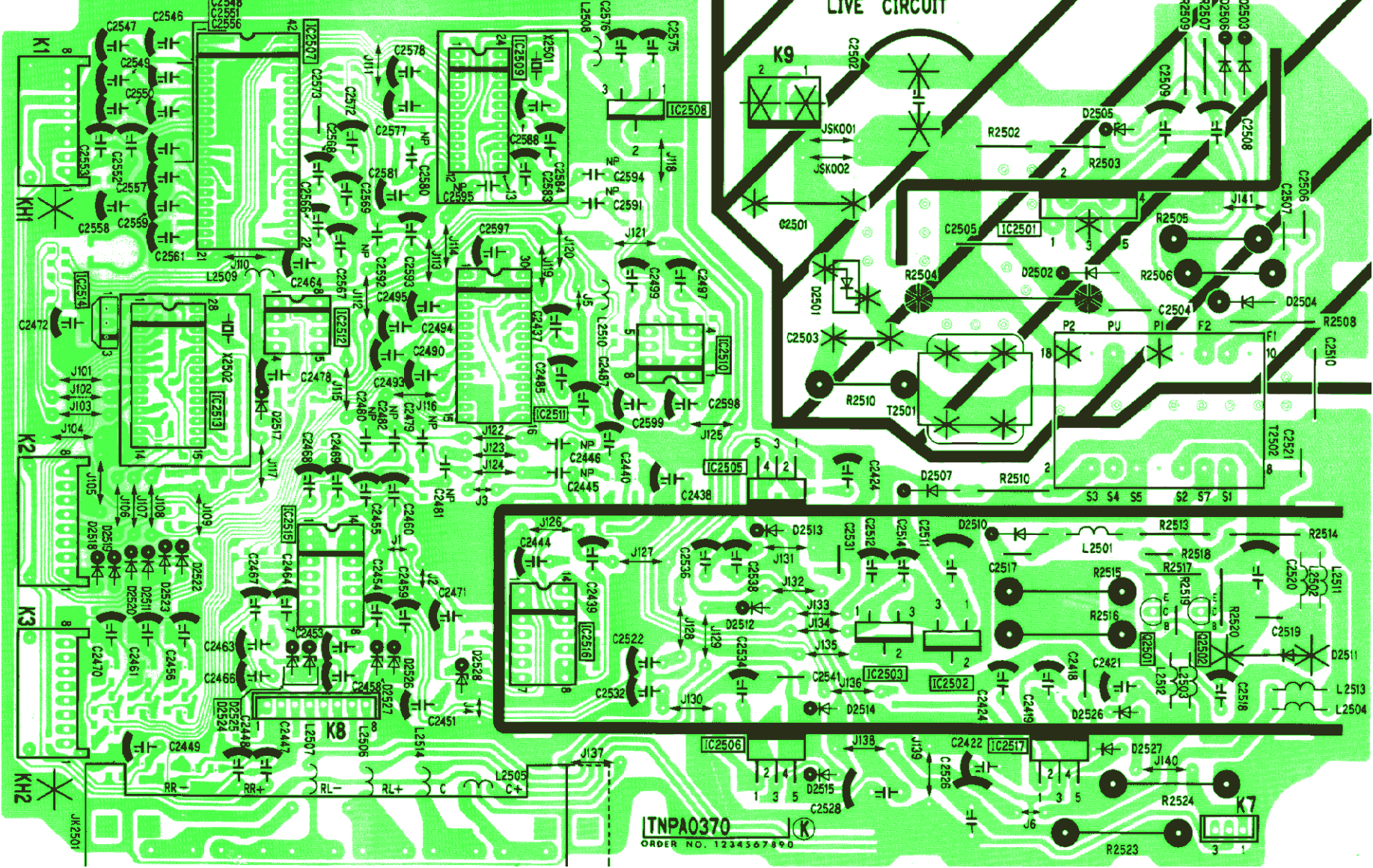

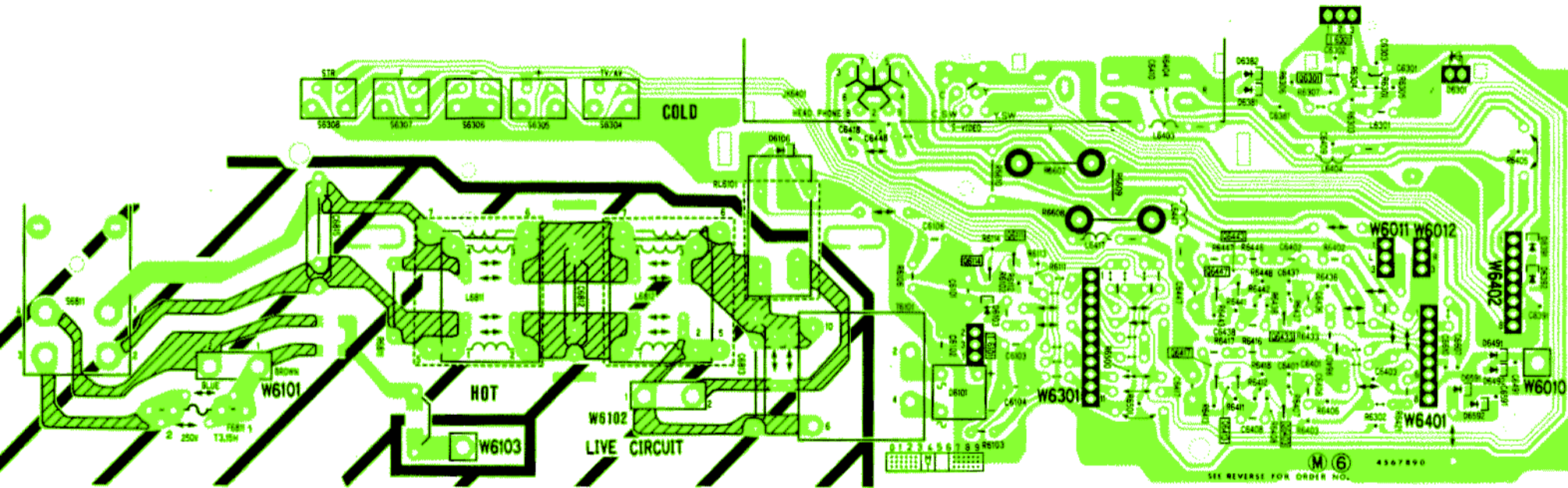

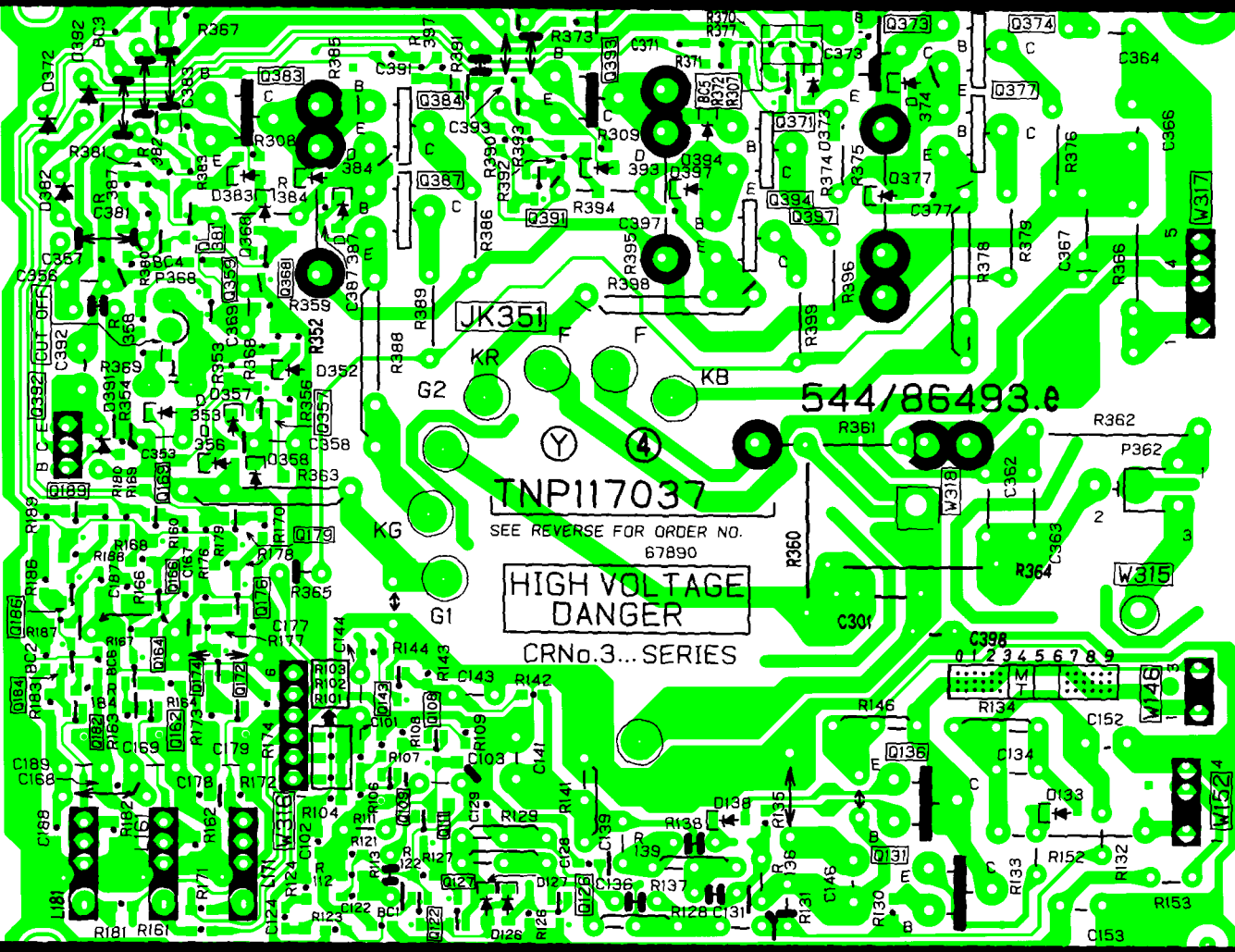

JK351

544/86493.0

TNP117037

SEE REVERSE FOR ORDER NO.
67890

HIGH VOLTAGE
DANGER

CRNo.3... SERIES

0181
0182
0183
0184
0185
0186
0187
0188
0189
0190
0191
0192
0193
0194
0195
0196
0197
0198
0199
0200
0201
0202
0203
0204
0205
0206
0207
0208
0209
0210
0211
0212
0213
0214
0215
0216
0217
0218
0219
0220
0221
0222
0223
0224
0225
0226
0227
0228
0229
0230
0231
0232
0233
0234
0235
0236
0237
0238
0239
0240
0241
0242
0243
0244
0245
0246
0247
0248
0249
0250
0251
0252
0253
0254
0255
0256
0257
0258
0259
0260
0261
0262
0263
0264
0265
0266
0267
0268
0269
0270
0271
0272
0273
0274
0275
0276
0277
0278
0279
0280
0281
0282
0283
0284
0285
0286
0287
0288
0289
0290
0291
0292
0293
0294
0295
0296
0297
0298
0299
0300
0301
0302
0303
0304
0305
0306
0307
0308
0309
0310
0311
0312
0313
0314
0315
0316
0317
0318
0319
0320
0321
0322
0323
0324
0325
0326
0327
0328
0329
0330
0331
0332
0333
0334
0335
0336
0337
0338
0339
0340
0341
0342
0343
0344
0345
0346
0347
0348
0349
0350
0351
0352
0353
0354
0355
0356
0357
0358
0359
0360
0361
0362
0363
0364
0365
0366
0367
0368
0369
0370
0371
0372
0373
0374
0375
0376
0377
0378
0379
0380
0381
0382
0383
0384
0385
0386
0387
0388
0389
0390
0391
0392
0393
0394
0395
0396
0397
0398
0399
0400
0401
0402
0403
0404
0405
0406
0407
0408
0409
0410
0411
0412
0413
0414
0415
0416
0417
0418
0419
0420
0421
0422
0423
0424
0425
0426
0427
0428
0429
0430
0431
0432
0433
0434
0435
0436
0437
0438
0439
0440
0441
0442
0443
0444
0445
0446
0447
0448
0449
0450
0451
0452
0453
0454
0455
0456
0457
0458
0459
0460
0461
0462
0463
0464
0465
0466
0467
0468
0469
0470
0471
0472
0473
0474
0475
0476
0477
0478
0479
0480
0481
0482
0483
0484
0485
0486
0487
0488
0489
0490
0491
0492
0493
0494
0495
0496
0497
0498
0499
0500

0374
0377
0378
0379
0380
0381
0382
0383
0384
0385
0386
0387
0388
0389
0390
0391
0392
0393
0394
0395
0396
0397
0398
0399
0400
0401
0402
0403
0404
0405
0406
0407
0408
0409
0410
0411
0412
0413
0414
0415
0416
0417
0418
0419
0420
0421
0422
0423
0424
0425
0426
0427
0428
0429
0430
0431
0432
0433
0434
0435
0436
0437
0438
0439
0440
0441
0442
0443
0444
0445
0446
0447
0448
0449
0450
0451
0452
0453
0454
0455
0456
0457
0458
0459
0460
0461
0462
0463
0464
0465
0466
0467
0468
0469
0470
0471
0472
0473
0474
0475
0476
0477
0478
0479
0480
0481
0482
0483
0484
0485
0486
0487
0488
0489
0490
0491
0492
0493
0494
0495
0496
0497
0498
0499
0500